

INSTALLATION INSTRUCTIONS

INSTALL INSTRUCTIONS PT-A-921

100 CFM PRISONER TRANSPORT POWER VENT

TOOLS REQUIRED:

- | | |
|----------------------------|-------------------------|
| 1/2" Power drill | Tape measure |
| 4 1/2" Hole saw | T-25 Torx Screwdriver |
| 3/4" hole saw or drill bit | Phillips screwdriver |
| Drill bit set | Silicone & Silicone Gun |

PARTS and MOUNTING HARDWARE:

<u>QTY</u>	<u>DESCRIPTION</u>	<u>PART#</u>
1	Upper hood cover plate	23525
1	Lower vent plate	23533
1	2 position switch rocker switch	13994
1	Under dash switch bracket	C-UDB-1
1	"Power Vent" switch label	23799
2	4" Hose clamp	15820
12"	4" Air Duct hose	16745
4	#10 Flat washer	16152
14	#10 x 3/4" Round head T-25 Torx screw SS	23922
1	3/8" Snap grommet	15791

Note: Due to supplier issues, some fans may arrive with a 4-wire plug preinstalled. Cut off the plug, tape off the two unused wires, and proceed with installation as normal.

Always!

- Read all instructions before installing any Havis, Inc. products.
- **Check for obstructions (Wires, brake lines, fuel tank, roof ribs, etc.) before drilling any holes!**
 - Use hardware provided with install kit

PT-A-921 Assembly

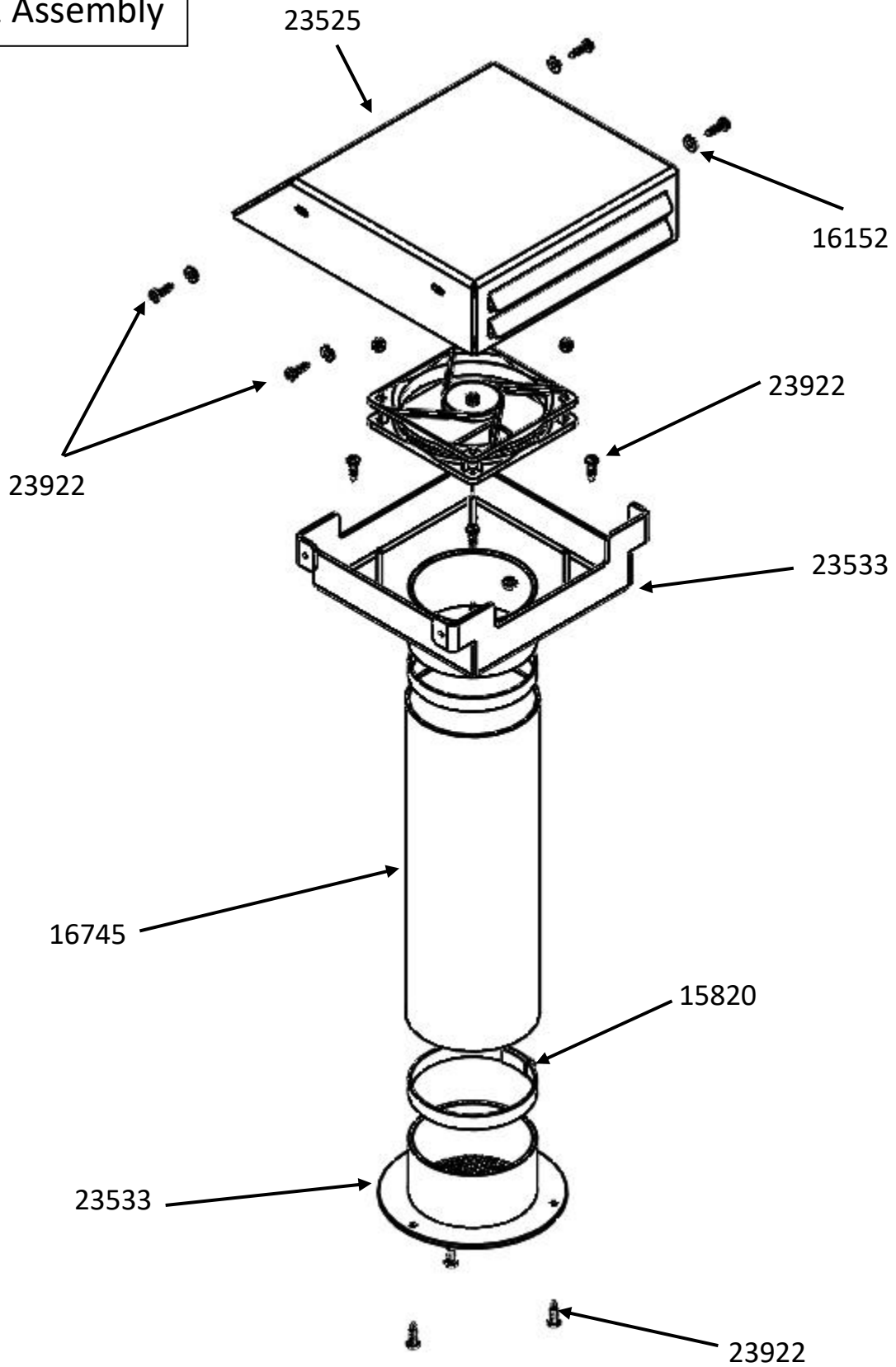

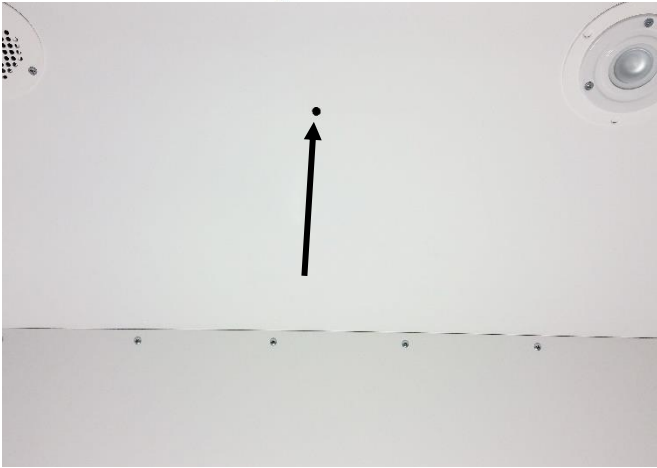

Measure between dome light vent plates.

Note: Make sure there is enough clearance away from van roof support beam for the 4 ½" vent hole.



Drill a 1/4" hole through the ceiling.



Insert a long screwdriver or punch through the hole and contact the roof of the van.



Tap a few times with a mallet to dimple the roof.



Locate the dimple on the roof; dimple will not be centered between roof ribs. Measure center between the ribs using dimple as a guide and mark.



Drill pilot hole through roof at previously measured mark.



Using a 4 1/2" hole saw, drill hole through roof of van. Wax lubricant on saw is recommended.



Deburr hole and clean off metal chips.

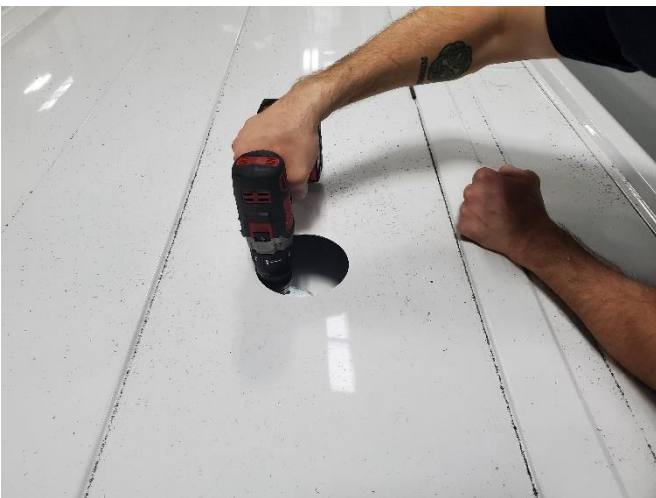

Drill hole through ceiling of insert using previously drilled 1/4" hole as a guide. This can be done through the hole in the roof or from inside the kit.



Deburr the hole in the ceiling to eliminate rough edges.

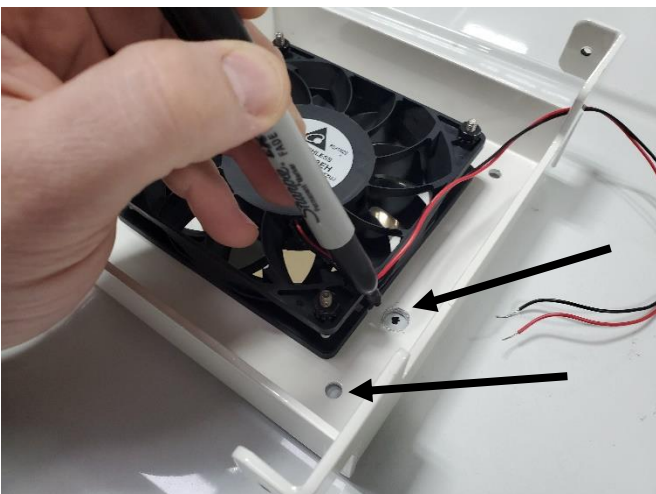

Place lower vent plate on roof and mark wire pass-through hole and mount hole locations.



Drill a 3/4" hole in roof for grommet clearance and drill 1/8" pilot holes for mount screws
Thoroughly clean metal chips off roof.



Attach flexible air duct hose to lower vent plate using hose clamp. Insert grommet and connect wiring. (Red - Positive / Black – Ground)



Caulk around holes on vehicle roof.



Slide hose through hole in roof. Clamp may need to be inserted at a slight angle to fit through opening in roof.

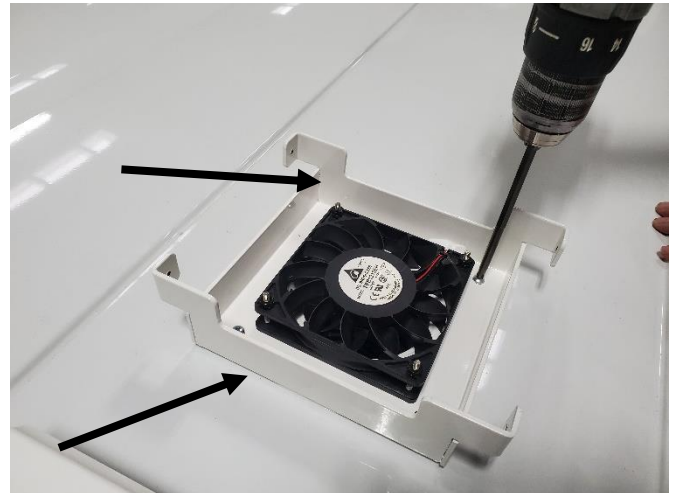

Use #10 Torx screws to attach lower vent plate to roof.
Caulk inside corners of vent plate.
Caulk around outside seams of vent plate.



Place cover on lower vent plate and attach together using #10 Torx screws and washers.
Note: Louvers go toward rear of vehicle.



Pull air duct hose through hole in ceiling and cut off excess.



Slide hose clamp over air duct hose and attach hose to vent cover.



Slide air duct and vent cover into ceiling of kit.
Mark and drill 5/32" mount holes



Use supplied #10 Torx screws to attach cover to ceiling of kit.



Confirm all hardware is tight and test power vent.



Installation is now complete.



Installation is now complete.