

# INSTALLATION INSTRUCTIONS

## P-MID-2 Middle Partition with P-MFK-12 Mount kit

### FOR 2015-2026 FORD TRANSIT STANDARD and LONG Wheelbase Vans with LOW ROOF

#### NOTES:

- **Will not fit in 5 passenger “Transit Crew Van”** with extra WIDE first row bench seat.
- **Will only work on the (2) and (3) person NARROW seat configurations for the first row bench seats included with 8, 10, 12, 14 and 15 passenger wagons.**

#### TOOLS REQUIRED:

Power Drill	Ratcheting Wrench
Drill Bit set	Phillips Screw Driver
Metric Socket Set	7/16” wrench

#### PARTS & HARDWARE:

QTY	DESCRIPTION	PART#
1	Front partition assembly	P-MID-2
<b>P-MFK-12</b>		
1	Seat delete block off plate	HS-PA007323
1	Driver side upper bracket	HS-PA007311-DS
1	Passenger side upper bracket	HS-PA007311-PS
4	1/4" Serrated nut	GSM30023
4	1/4 x 1/2" Carriage bolt	GSM31999
10	#10 x 1" Screw	GSM33196
12	#10 x 1.25" Screw	GSM34157
6	1/4" X 1" Lag screw	GSM33060



#### Always!

- Read all instructions before installing any Havis, Inc. products.
- **Check for obstructions (Wires, brake lines, fuel tank, etc.) before drilling any holes!**
  - Use hardware provided with install kit

HS-PA007311-PS  
Passenger upper partition bracket

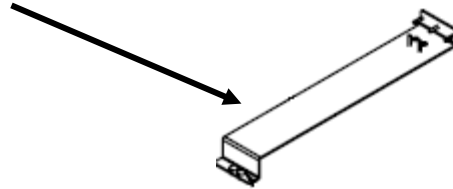

HS-PA007323  
Floor Mounted  
Seat delete block off plate

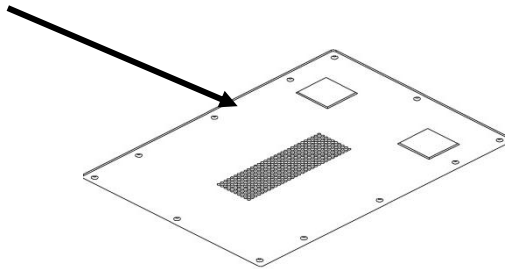

P-MID-2  
Middle partition assembly

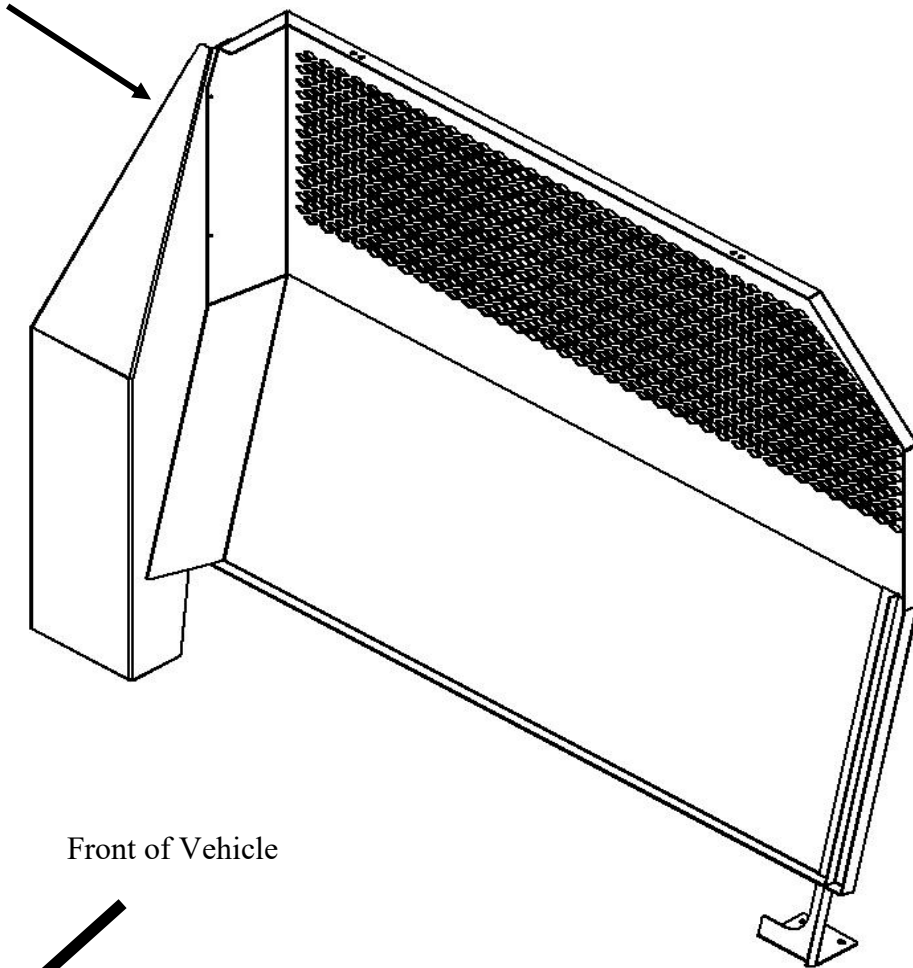

HS-PA007311-DS  
Driver upper partition bracket

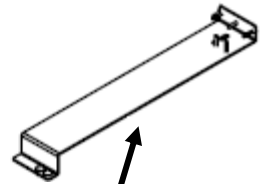

Front of Vehicle

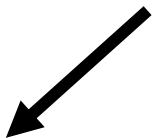



Removal of the small single seat is needed to allow access to the rear seats once the partition is installed.

**NOTE:** 8 passenger wagon has second row full bench seat that cannot be removed, but entry/exit still works OK.



Mount block off plate (HS-PA007323) to floor. Carefully drill floor with 1/8 bit and attach with twelve (12) #10 x 1.25" screws (GSM34157)

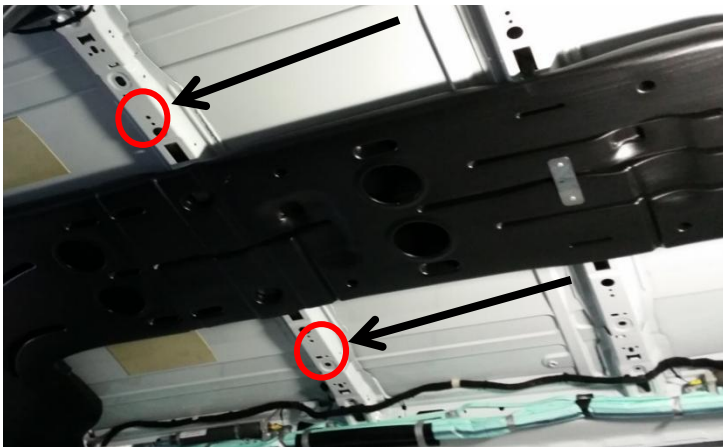

With headliner removed line up the upper mounting brackets to the ribs in the roof. The brackets will only line up to one spot.

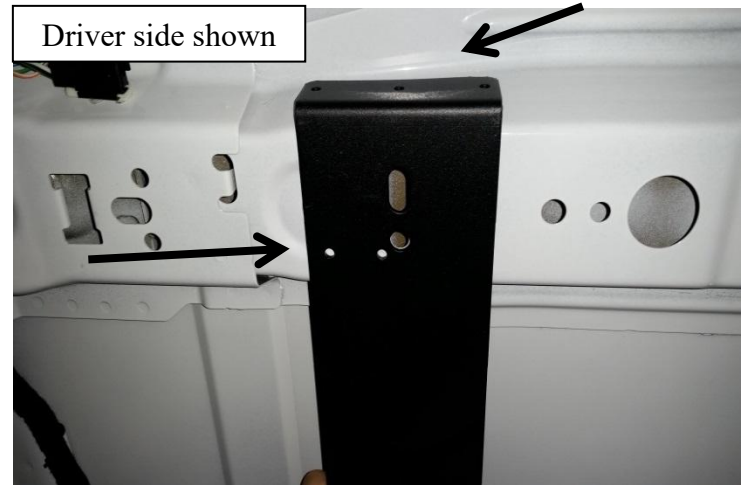

With the bracket lined up to the OEM holes in rib, mark and carefully drill five (5) holes in the rib. Attach bracket using #10 x 1" screws GSM33196



Repeat mounting process for passenger side.  
**Note:** The alignment holes determine the driver and passenger side brackets.

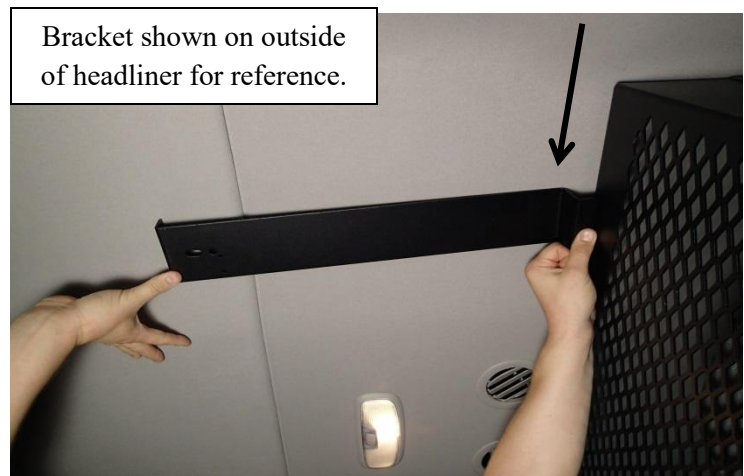

The bracket is designed to fit between the headliner and the roof. The forward angle of the bracket will come through the headliner where it attaches to the partition. The headliner will need to be cut for bracket to come through in this spot.



With the upper brackets installed slide the partition into the van and attach to the upper brackets using 1/4 x 1/2" carriage bolts and 1/4" nuts.

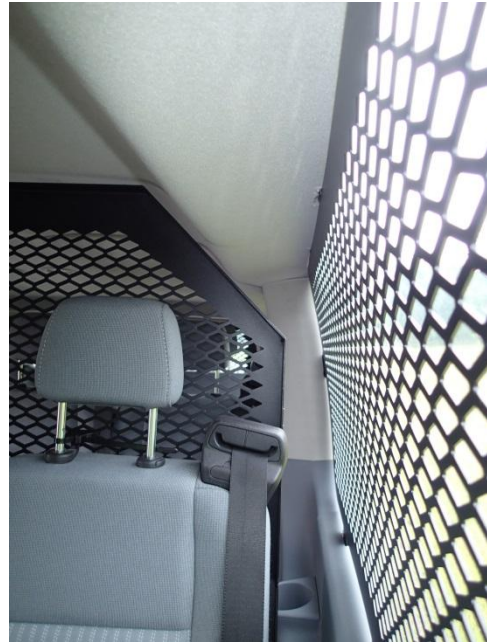

To allow for side curtain airbag deployment, side filler panels are not available for the middle partition.



Carefully drill and attach mounting flange to passenger side floor using three (3) 1/4" x 1" lag



Carefully drill and attach driver side mounting foot to floor using three (3) 1/4" x 1" lag screws.



Completed P-MID-2  
Middle Partition installation



Completed P-MID-2  
Middle Partition installation