

Pure Sine Wave Ambulance Inverter/Charger

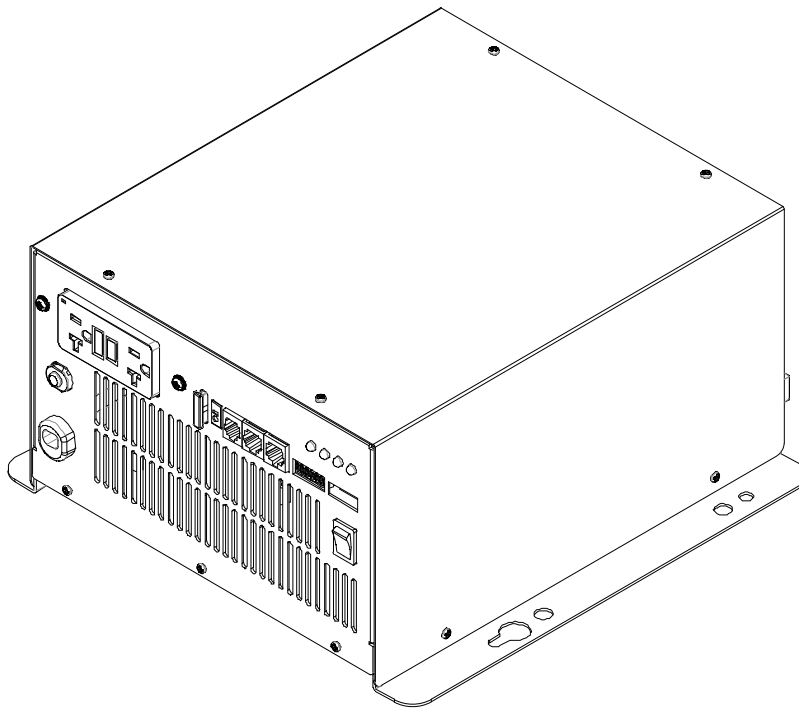

Model LSC12-1100

SECTION 1: GENERAL INSTALLATION DIAGRAM

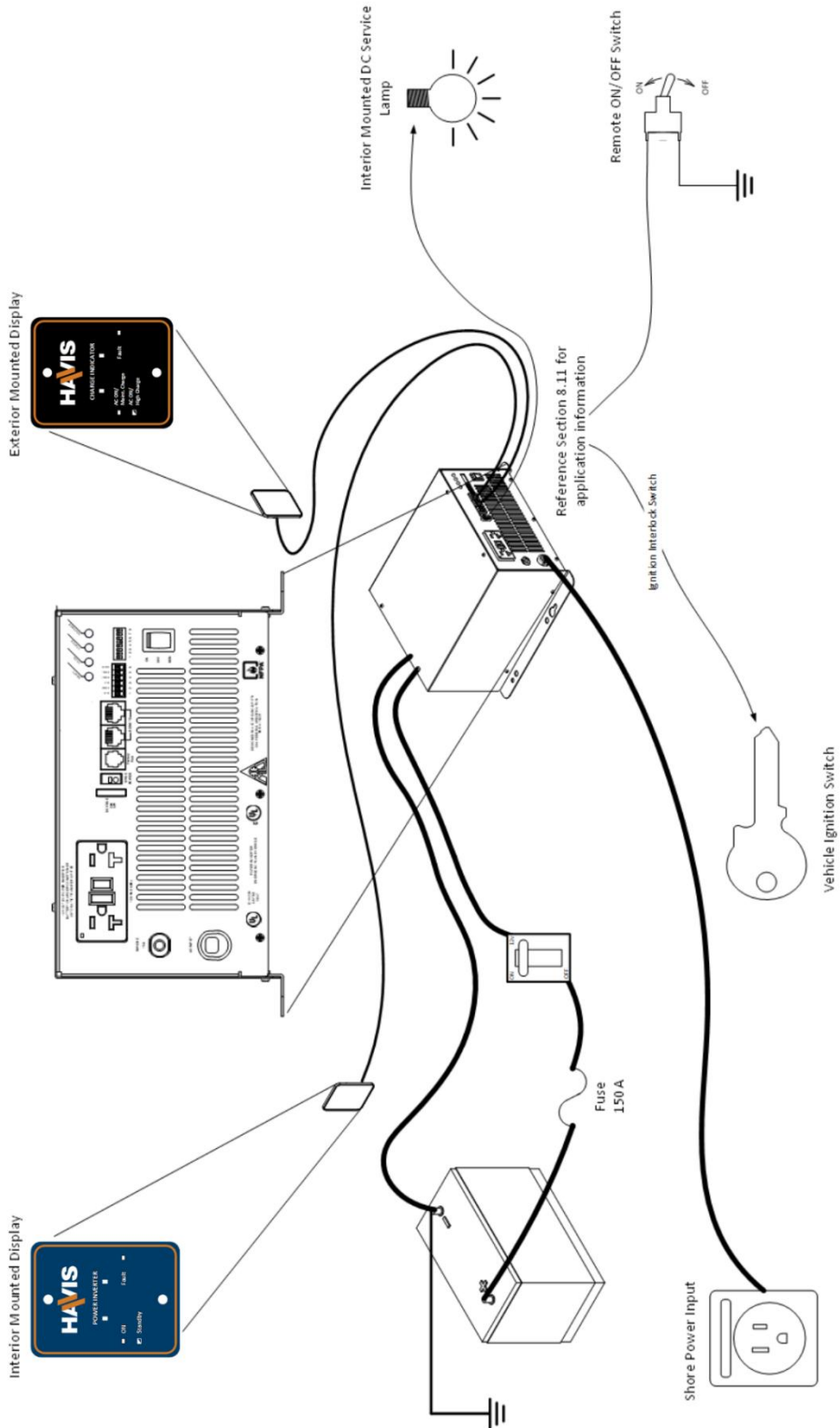

Table of Contents

Section 1: General Installation Diagram	2
Section 2: Introduction	4
Section 3: Specifications	5
Section 4: Functionality	6
Section 5: Physical Dimensions	10
Section 6: Front and Rear Panel Component.....	11
Section 7: IMPORTANT SAFETY INSTRUCTIONS.....	16
Section 8: Installing the LSC12-1100.....	18
Section 9: Installation and function of the LSCR and LSIR.....	22
Section 10: Operating the LSC12-1100	24
Section 11: Fault Shutdown Conditions and Solutions.....	25
Section 12: Troubleshooting the LSC12-1100.....	26

SECTION 2: INTRODUCTION

Thank you for purchasing a Havis LSC12-1100 true sine wave Ambulance Inverter/Charger for your emergency vehicle. We are confident you will be satisfied with its performance.

Havis products are designed and manufactured by skilled professionals using the highest standards in workmanship, guaranteeing excellent performance and reliability for your emergency vehicle. With minimum maintenance and care, you can expect years of trouble-free service from your Havis product.

The LSC12-1100 is a 12 VDC to 120 VAC true sine wave inverter with built-in battery charger, transfer relay, and KKK Spec 12VDC Portable Equipment Charging Circuit. The unit is equipped with an AC input line cord for connecting to AC input power (shore/utility power) and equipped with a Ground Fault Circuit Interrupter (GFCI) receptacle for AC output. This allows AC loads to be connected directly to the inverter. The DC input uses an Anderson style two-pole quick connector to facilitate installation and pre-wiring of emergency vehicles. The 12V Portable Equipment Charging Circuit has a spring clamp for ease of output connection. **The unit must be connected to the DC source for the transfer relay and battery charger to work correctly.**

SECTION 3: SPECIFICATIONS

Inverter		LSC12-1100	
Continuous Output Power Rating	1100 Watts (9.2 amps)		
Surge Capacity (3 sec)	1650 Watts		
DC Input Voltage, VDC	12 VDC Nominal, 10.5 VDC min, 16.5 VDC max.		
AC Output Voltage	120 VAC \pm 5%		
AC Output Wave Form	True Sine Wave (THD < 3% @ linear load)		
AC Output Frequency	60 Hz or 50 Hz, \pm 0.3 Hz, User Selectable		
DC Current Draw from Battery			
Inverter OFF	0.0 Amps		
Inverter ON in Load Demand	Approx. 0.08 Amps		
Inverter ON, Load Demand OFF, with No AC Load	Approx. 1.4 Amps		
Inverter ON with AC Load	Approx. AC Load Watts \div 10		
Battery Charger			
AC Input Voltage	120 VAC Nominal (90VAC min, 132VAC max)		
DC Input Voltage	Minimum 9.0VDC		
AC Input Frequency	60Hz or 50Hz, \pm 3 Hz		
AC Input Amps	7.5 Amps AC Max (Approx. DC Output Amps \div 7)		
Charging Capacity (Includes 12V DC Output Power Source)	12 Amps DC, 25A, 37A, or 50A, User Selectable		
Battery Type *	Flooded	AGM	LiFePO4
Bulk Voltage	14.2 VDC	14.4 VDC	14.4 VDC
Absorption Voltage	14.1 VDC	14.3 VDC	14.4 VDC
Float Voltage	13.2 VDC	13.6 VDC	14.0 VDC
Bypass Transfer Switch Rating			
AC Output Current to GFCI Output Receptacle	12 Amps AC		
Automatic Power Management			
Maximum AC Current Drawn from Shore Power	12 Amps AC (Battery Charging is reduced as needed.)		
12V DC Output Power Source			
Output Voltage	Battery Voltage		
Output Current	20 Amps DC Max. (Subtract Power Source output amps from Charging Capacity)		
Other Specifications			
AC Input Termination**	3 Ft 120 VAC 15 Amp Line Cord		
AC Output Termination ***	Duplex GFCI Receptacle		
DC Input Termination	175 Amp Anderson Style Two-pole Connector		
Ambient Operating Temperature at full power	-4°F to +104°F		
Ambient Operating Temperature at de-rated power	De-rate to zero watts at +158°F		
Cooling	Air Cooled by Variable Speed Intake Fan		
Chassis	Aluminum		
Dimensions	11.57"W x 5.94"H x 11.4"D****		
Weight	9.5 pounds		
Safety Standards	Certified UL/cUL 458		

* DO NOT use GEL batteries if charging voltages do not meet the Battery Manufacturer's specifications. Consult GEL Battery Manufacturer before using GEL batteries.

** AC input branch rated overcurrent protection is to be provided by others to comply with the National Electric Code, NFPA 70.

*** If the GFCI trips while on inverter power and the Load Demand Feature is enabled, the GFCI cannot be re-set until the inverter is turned OFF and back ON. Turn the inverter OFF and back ON, and reset the GFCI within 10 seconds before the inverter goes back into Load Demand mode.

**** Allow approx. 3.5" clearance behind the inverter for access to connect/disconnect the Anderson connector.

SECTION 4: FUNCTIONALITY



WARNING : The LSC12-1100 will be damaged if battery positive and battery negative are connected to the inverter backwards.

Inverter Function

The LSC12-1100 converts 12VDC battery power to 1100 Watts of true sine wave 120V AC power to operate vital emergency vehicle equipment.

If the inverter is overloaded it will shut down for three seconds and attempt to restart. After 5 shutdown/restart attempts the inverter will shut down and latch OFF. The inverter must be turned OFF/ON to reset.

If battery voltage goes above 16.5V, or momentarily goes below 10.5V the inverter will shut down and will automatically restart when voltage comes back within operating range. If voltage stays below 10.5V the inverter will shut down and latch OFF. The inverter must be turned OFF/ON to reset.

Remote Control

Remote control capability is built in for ON/OFF control of the inverter function. (Remote control has no effect on the battery charger or transfer switch functions.) The unit is designed to accept **one** customer supplied maintained remote control signal. The remote control signal may be +12V, GROUND, or two-wire CONTINUITY.

When retrofitting the LSC12-1100 into an older system that has two remote control signals, an automotive relay may need to be added. see Section 8: Installation; Step 11: Remote Control.

Load Demand

The Load Demand feature is not recommended for vehicle applications. The recommended Load Demand setting for ambulance is OFF. (DIP Switch 7 OFF (DOWN.)) In vehicle applications many of the typical AC loads are too small to allow the inverter to come out of Load Demand mode (sleep mode) which would prevent those loads from receiving AC power.

With the Load Demand feature enabled, the inverter will go into Load Demand mode (go to sleep) when the AC load is below 20 watts and will come out of Load Demand mode (wake up) when the AC load is above 40 watts. While the inverter is in Load Demand mode (asleep) the inverter's voltage/power/status LED's and the inverter's AC output voltage are pulsed ON every ten seconds. The Load Demand feature is useful in some "backup power" applications, such as for an unattended sump pump, where the inverter's total AC load is zero watts for long periods of time. In sump pump back-up power applications Load Demand may significantly reduce the power drawn from the battery and therefore extend backup time during a power outage.

If the GFCI receptacle trips while the Load Demand feature is enabled, the inverter will go into Load Demand mode (go to sleep) since the inverter will not see any AC load. The GFCI receptacle's reset button does not work while the inverter is in Load Demand mode since AC power is not present. To reset the GFCI, turn the inverter OFF and ON, and reset the GFCI within 10 seconds. The inverter always starts up "out of Load Demand mode" for 10 seconds.

Battery Charger

The LSC12-1100 incorporates an energy-efficient three-stage battery charger. This design enables the unit to automatically charge batteries, maintaining the battery's integrity and reducing the likelihood of premature failure.

The LSC12-1100 charger is an extremely efficient PFC (Power Factor Corrected) and PI (Proportion-Integral) multi-stage battery charger. The PFC feature controls the amount of power used to charge the batteries to obtain a power factor as close as possible to 1 (or unity). This causes the battery charger to look like a resistor to the line (forces the charge current wave shape to mirror the voltage wave shape). The PI feature allows the charger voltage and current to change independently. These two energy-efficient features maximize the real power available from the AC power source (shore power) which translates into less power wasted and greater charging capabilities than other chargers.

The battery charger is "controlled" by the presence of AC input power. Charge Mode begins when AC input power is accepted. The battery charger is not controlled by the inverter ON/OFF switch or the inverter remote control. In battery charging mode, all four status LED's will be on.

Charging Amps and Battery Type are selectable using the Setup DIP Switch located on the front of the inverter. Charging voltages are determined by the battery type selected. The factory setting for charging amps is 50 amps. This is the recommended setting for ambulance. The factory setting for Battery Type is Flooded.

Note: After making a change to the Setup DIP Switch settings, shore power must be removed and the inverter must be cycled OFF/ON for the change to go into effect.

The LSC12-1100 must be connected to the battery and battery voltage must be above 9.0V for the charger/transfer switch to turn ON. The battery charger function WILL NOT TURN ON if battery voltage is below 9.0V. If battery voltage is below 9.0V, it will be necessary to momentarily "jump" the battery so the charger can turn ON.

Transfer Switch

When the AC input cord is connected to an AC source (shore power), the inverter begins monitoring for acceptable AC input power. After the AC input power is accepted the built-in AC TRANSFER SWITCH changes the source for the inverter's GFCI receptacle from inverter power to shore power. Shore power will then be supplying power to the GFCI receptacle. The TRANSFER SWITCH switches both HOT and NEUTRAL so the NEUTRAL-to-GND bond is in effect only at the source of AC power. The source of AC power is the inverter when on inverter power, and is the shore circuit breaker panel when on shore power.

Automatic Power Management

The purpose of this feature is to try to limit the load on shore power to 12AC amps. The load on shore power consists of the "pass through loads", which are the AC loads receiving power from the inverter's GFCI receptacle, combined with the AC power (approx. 7.5 amps AC max) being consumed by the battery charger. Automatic Power Management will reduce battery charger power (reduce DC charging output amps) as needed so the load on shore power does not exceed 12 AC amps. If the "pass through loads" exceed 12 AC amps, the battery charger power will be reduced to zero DC output amps and the LSC12-1100 will shut down for AC Input Over Current Shutdown.

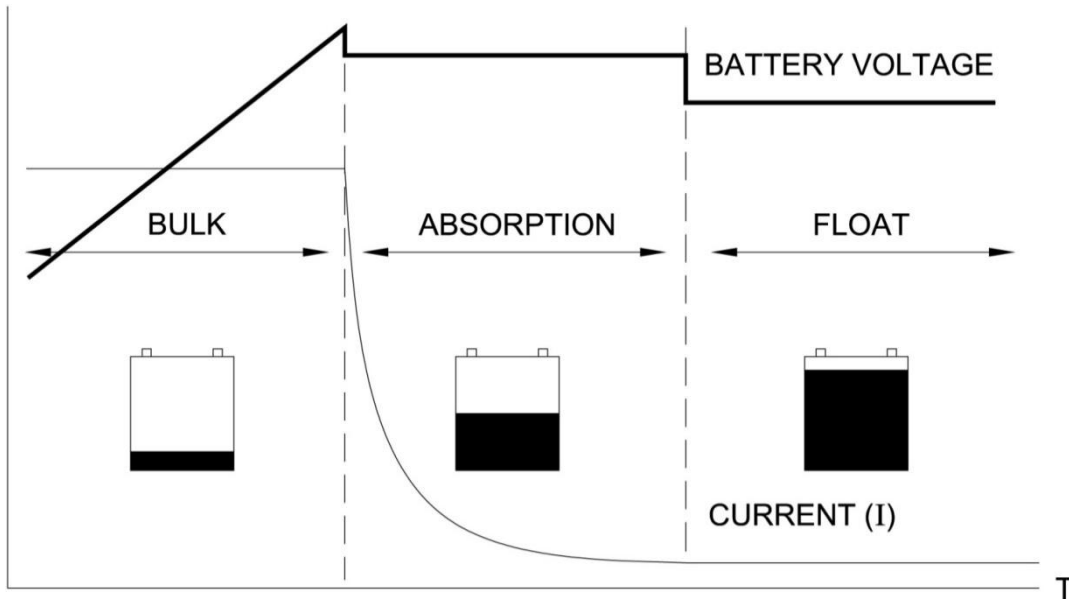

Three Stage Battery Charger Graph

Bulk Charging Stage

The battery charger always begins in the Bulk charge stage each time shore power is connected. In Bulk the charging current is held at the Charging Capacity amps. Battery voltage rises. Upon reaching Bulk Voltage, or after eight hours, Bulk charge stage ends and Absorption charge stage begins.

Absorption Charging Stage

Battery voltage is held at Absorption Voltage. Charging current varies as needed to hold battery voltage constant. After one hour, or when charging current falls below approx. 3.5 amps, Absorption ends and Float begins.

Float Charging Stage

Battery voltage is held at Float Voltage. Charging current varies as needed to hold battery voltage constant. The charger will switch to Bulk charge stage if charging current remains at "Bulk charging amps" for more than approximately 5-30 seconds.

12V DC OUTPUT POWER CIRCUIT

The LSC12-1100's 12V DC OUTPUT Power Circuit complies with KKK section 3.7.7.2 for PORTABLE EQUIPMENT CHARGING CIRCUIT. Which states "*A circuit shall be furnished for charging all portable battery powered devices, i.e. suction units, hand lights, portable radios, etc. This circuit shall prevent discharge of chassis batteries by only permitting the charging of portable devices when the vehicle is either running or the optional battery conditioner is connected to shore power. Circuit protection shall be provided and shall have a minimum 10 amp capacity. An additional tagged, identified lead shall be furnished in both the cab and module for connection of additional (future) portable equipment that requires recharging.*"

12V DC OUTPUT Power (battery power) is available in inverter mode when the inverter is ON, and in battery charger mode when acceptable shore power is present.

The 12V DC OUTPUT Power Circuit is protected by a 20 Amp ATO fuse labeled DC Fuse, located beside the output terminal on the front of the inverter.

SECTION 5: PHYSICAL DIMENSIONS

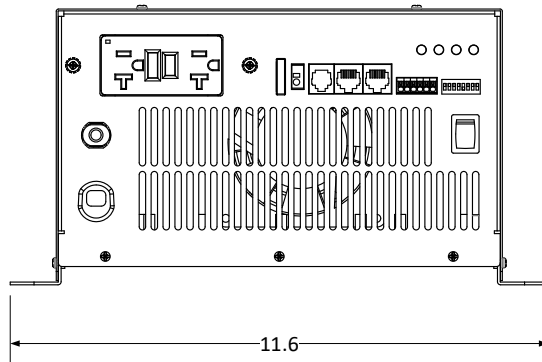
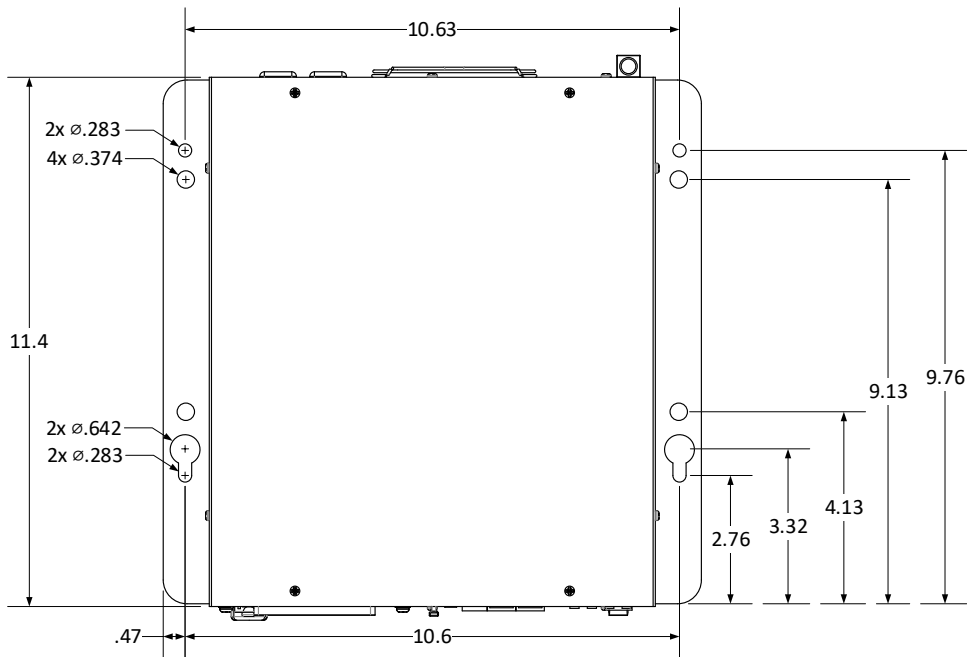
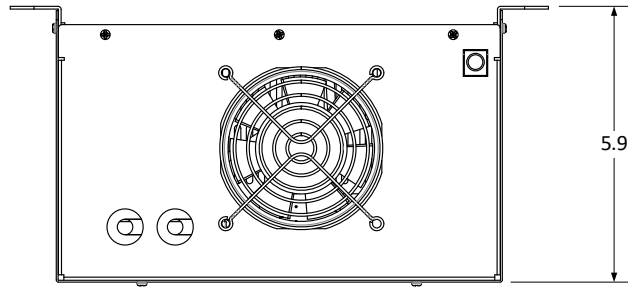

SECTION 6: FRONT AND REAR PANEL COMPONENT Identification and Description of Operation

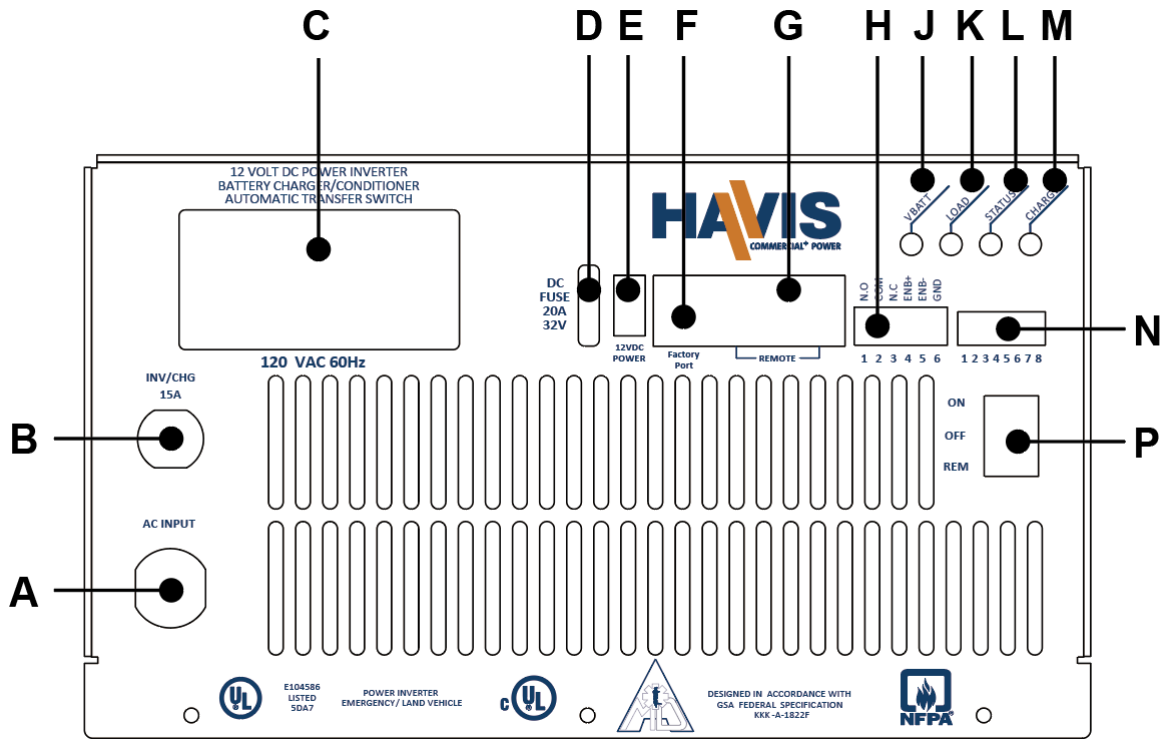

LSC12-1100 Front Panel Components	
A	AC Input Cord (125V/15A, 3FT Long)
B	15 AMP AC Input Circuit Breaker
C	AC Output GFCI Receptacle
D	20 Amp ATO Fuse protects 12V DC OUTPUT Circuit
E	12V DC OUTPUT Power Terminal
F	Communication Port for Factory Use Only (RJ11)
G	Remote Status Display Panel Ports, (Two RJ45)
H	Remote Control Terminals and Alarm Terminals
J	Status LED - Battery Voltage
K	Status LED - AC Load
L	Status LED - System Status
M	Status LED - Battery Charger
N	Setup DIP Switches
P	Inverter ON/OFF/REMOTE Switch

Item A: AC Input Cord (125v/15A, 3Ft Long)

Item B: 15 Amp AC Input Circuit Breaker

All AC input power from shore passes through this breaker. This breaker should not trip as long as AC loads plugged into the GFCI receptacle do not exceed 12 amps.

Item C: AC Output GFCI Receptacle

Item D: 20 Amp ATO Fuse Protects 12V DC OUPUT Power Circuit

Item E: 12V DC OUTPUT Power Terminal

See Section 4 for functionality

Item F: Communication port for Factory Use Only (RJ11)

Item G: Ports for optional LSIR and LSCR Remote Status Panels

Connect either remote status panel to either of these two RJ45 ports. Will also operate legacy IFM1 module remotes. NOTE IFM1 ON/OFF controls will not control the LSC12-1100.

Item H: Remote Control Terminals and Alarm Terminals

This six-position compression terminal block will accept up to 14ga wire. Connect by inserting the wire straight into bottom opening. Release wire by pressing the grooved button above the opening.

Terminal	Description	
1	Alarm Dry Contact	Normally Open
2	Alarm Dry Contact	Common
3	Alarm Dry Contact	Normally Closed
4	Remote Control ENB+	Accepts +12VDC Remote Control Signal
5	Remote Control ENB-	Accepts GND Remote Control Signal
6	Remote Control GND	Use with ENB- to accept two-wire Continuity Signal

Alarm Terminals 1, 2, and 3 are connected to a Form C (SPDT) relay for remote "FAULT" indication. When "FAULT" occurs, the relay switches. Contacts are rated 24vdc/250vac, 1 amp max resistive load.

Remote Control Terminals 4, 5, and 6 allow remote control of the inverter when the ON/OFF/Remote Switch is in the REMOTE position. **Connect only ONE remote control "enable" signal to the LSC12-1100.** Multiple signals will not harm the LSC12-1100 but will perform as parallel switches.

When retrofitting the LSC12-1100 into a system that has two remote control signals, see Section 8: Installation; Step 9: Remote Control,

Items J, K, L, M: Status LED's

LED	Color	Meaning
Battery Voltage	Red	<11.0V
	Orange	11.1 ~ 11.5V
	Green	11.6 ~ 15.0V
	Orange	15.1 ~ 15.5V
	Red	>15.5V
AC Load	Green	0 ~ 100 %
	Orange	100 ~ 115%
	Red	> 115%
System Status (See Section 11 Fault Shutdown Table for trouble shooting.)	Green	Inverter ON
	Green slow blink	Over Temperature Shutdown
	Orange	Phase Lock Loop / Frequency Fail
	Orange Slow Blink	AC IN Under or Over Voltage Shutdown
	Orange Fast Blink	AC IN Over Current Shutdown
	Red	Overload Shutdown Protection
	Red Slow Blink	Battery Under Voltage Shutdown
Red Fast Blink	Battery Over Voltage Shutdown	
Battery Voltage AC Load System Status	All three LED's blink ON for 0.5 second every 10 seconds	The inverter is in Load Demand Mode. (Load Demand is not recommended for vehicle applications.)
Battery Charger Stage	Orange Blink	Bulk
	Orange	Absorption
	Green	Float
	OFF	OFF
LSCR	Green Blink	Charger is in Bulk or Absorption
	Green	Charger is in Float
	Red	Fault
LSIR See more detailed chart in Section 9	Green Blink	The inverter is in Stand By. Shore power is ON and supplying power to the AC load. The inverter will turn ON and supply power to the AC load if shore power is lost.
	Green	Inverter is ON
	Red	Fault

If a fault occurs, the unit will temporarily shut down and try to restart approximately 3 times. If the fault remains, the unit will latch OFF. Reset the unit by turning it OFF and back ON.

Item N: Setup DIP Switch

Use the 8-Positin Setup DIP Switch to select:

- AC output frequency
- Battery Charging Current
- Battery Type
- Load Demand Feature ON/OFF
- 12VDC Output Power Feature ON/OFF

This DIP Switch Function Diagram is silk screened onto the top of the inverter.

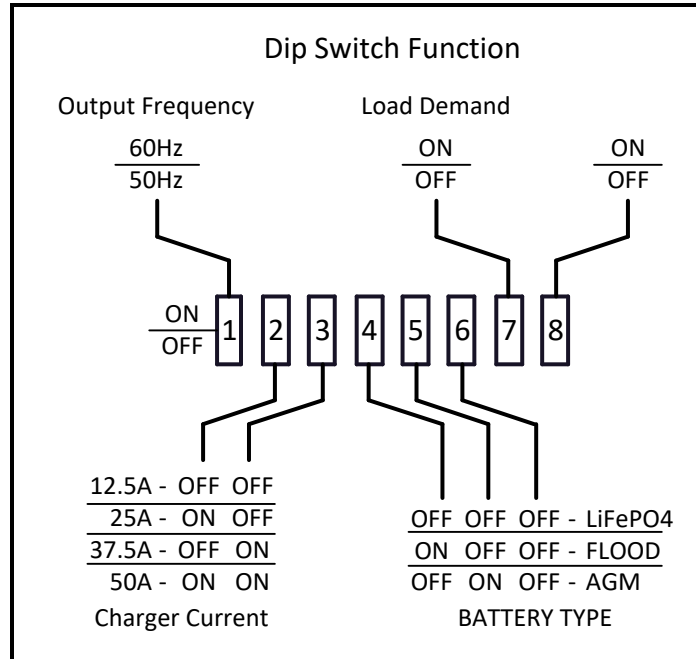

The factory DIP Switch settings are: **1, 2, 3, 4 and 8, ON (UP); 5, 6 and 7, OFF (DOWN).**

The factory settings select:

AC Output Frequency.....	60Hz
Battery Charging Current.....	50Amps
Battery Type.....	Flooded
Load Demand Feature.....	OFF
12VDC Output Power Circuit....	ON

Note: After making any change to the Setup DIP Switch settings, shore power must be disconnected and the inverter must be turned OFF and back ON for the change to go into effect.

Item P: Inverter ON/OFF/REMOTE Switch

The ON/OFF/REMOTE Switch provides ON/OFF control for the inverter. This switch has no control over the battery charger or transfer switch functions. Set the switch to the ON position to turn the inverter ON. Set it to the OFF position to turn the inverter OFF. Set it to the REMOTE position to enable inverter remote control.

If the unit has shut down for a fault, reset the inverter by cycling the ON/OFF/REMOTE Switch OFF and back ON, or, if there is a remote switch, by cycling a remote switch OFF/ON.

Rear panel

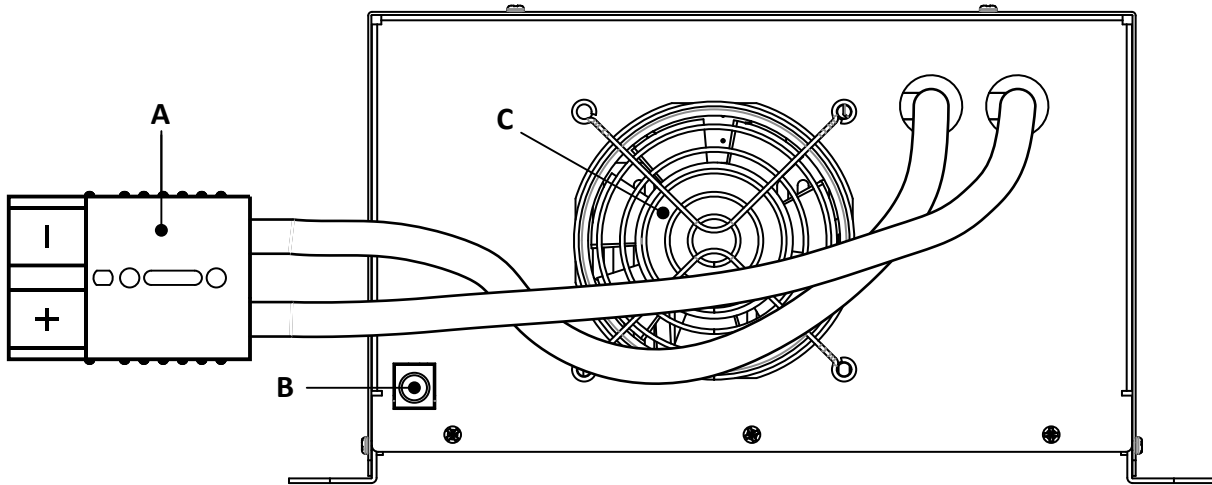

LSC12-1100 View of back panel and intake fan	
A	DC input connector (175 AMP Anderson Connector)
B	Chassis ground
C	Cooling Air Intake Fan and Finger Guard

SECTION 7: IMPORTANT SAFETY INSTRUCTIONS



SAVE THESE INSTRUCTIONS: This manual contains important safety and operating procedures.

1. **CAUTION** – To reduce risk of injury, charge only Flooded, AGM/GEL, or LiFePO4 batteries. Other types of batteries may burst causing personal injury and damage.
2. Do not expose the unit to rain or snow.
3. Use of an attachment not recommended or sold by the manufacturer may result in a risk of fire, electric shock, or injury to persons.
4. Do not disassemble unit. Return to Havis when service or repair is required. Incorrect reassembly may result in a risk of electric shock or fire.
5. To reduce risk of electric shock, unplug unit from outlet before attempting any maintenance or cleaning. Turning off controls will not reduce this risk.
6. **WARNING** – RISK OF EXPLOSIVE GASES.
 - a) **WORKING IN VICINITY OF A LEAD-ACID BATTERY IS DANGEROUS. BATTERIES GENERATE EXPLOSIVE GASES DURING NORMAL BATTERY OPERATION. FOR THIS REASON, IT IS OF UTMOST IMPORTANCE THAT EACH TIME BEFORE SERVICING THE UNIT IN THE VICINITY OF THE BATTERY, YOU READ THIS MANUAL AND FOLLOW THE INSTRUCTIONS EXACTLY.**
 - b) To reduce risk of battery explosion, follow these instructions and those published by battery manufacturer and manufacturer of any unit you intend to use in vicinity of battery. Review cautionary marking on these products and on engine.
7. **PERSONAL PRECAUTIONS AROUND BATTERIES**
 - a) Someone should be within range of your voice or close enough to come to your aid when you work near a lead-acid battery.
 - b) Have plenty of fresh water and soap nearby in case battery acid contacts skin, clothing, or eyes.
 - c) Wear complete eye protection and clothing protection. Avoid touching eyes while working near battery.
 - d) If battery acid contacts skin or clothing, wash immediately with soap and water. If acid enters eye, immediately flood eye with running cold water for at least 10 min and get medical attention immediately.
 - e) NEVER smoke or allow a spark or flame in vicinity of battery or engine.
 - f) Be extra cautious to reduce risk of dropping a metal tool onto battery. It might spark or short-circuit battery or other electrical part that may cause explosion.
 - g) Remove personal metal items such as rings, bracelets, necklaces, and watches when working with a lead-acid battery. A lead-acid battery can produce a short-circuit current high enough to weld a ring or the like to metal, causing a severe burn.
 - h) NEVER charge a frozen battery.
 - i) If removing battery from vehicle, always remove grounded terminal from battery first. Make sure all accessories are off so as not to cause an arc.
 - j) Be sure area around battery is well ventilated.
 - k) Clean battery terminals. Be careful to keep corrosion from coming in contact with eyes.
 - l) Follow all battery manufacturer's specific precautions such as removing or not removing cell caps while charging and recommended rates of charge
 - m) For flooded batteries, add distilled water in each cell until battery acid reaches level specified by battery manufacturer. This helps purge excessive gas from cells. Do not overfill. For

a battery without cell caps, carefully follow manufacturer's recharging instructions.

8. UNIT LOCATION

- a) Locate unit away from battery in a separate, well ventilated compartment.
- b) Never install unit directly above battery. Gases from battery will corrode and damage unit.
- c) Never allow battery acid to drip on unit when reading gravity or filling battery.
- d) Do not operate unit in a closed area or an area having restricted ventilation.

9. DC CONNECTION PRECAUTIONS

Connect and disconnect DC output connections only after turning unit OFF and removing shore power.

11. GROUNDING INSTRUCTIONS

The chassis of this unit should be connected to vehicle chassis. Connections to unit should comply with all local codes and ordinances.

SECTION 8: INSTALLING THE LSC12-1100

Unpacking

1. Inspect the shipping container and equipment for loose or damaged parts. If any damage is found, immediately notify the freight carrier.
2. An Accessory Pack is included with the LSC12-1100 that contains the necessary Anderson style DC cable connector and associated parts. The Accessory Pack includes:
 - Qty 1 – Havis #02216 Two Pole 175Amp Anderson Style Gray Connector housing which comes with two Havis #02215 contacts for 1/0 cable
 - Qty 2 - Havis #02217 Reduce Bushing, 1/0 to 2 GA
 - Qty 1 - Havis #02218 Strain Relief Clamp
 - Qty 4 - Havis #04864 Screw, #14 x 1"
 - Qty 1 - Havis #014801 Screwdriver

Installation

3. Verify the inverter ON/OFF/Remote switch is in the OFF position. Make sure power to the vehicle wiring harness is disconnected.
4. Select a location for the unit. An ideal installation location has the following characteristics:
 - Close to the battery (not in the same enclosure)
 - Protected from the weather
 - Well ventilated

Cooling air enters at the back of the unit and exits through the front of the unit. For maximum performance the location should minimize recirculating the same hot air through the unit.

5. Route DC input cables.

Route the negative and positive DC input cables from the inverter quick connector to the battery. Protect cables where they contact hard, sharp edges.

DC Cable Length	
Size (AWG)	Maximum Distance (FT)
2 AWG	12ft
1/0	20ft

6. Fusing.

Install an inline fuse, purchased separately, in the positive DC input cable from the battery to the inverter. The fuse should be located ***within 18 inches of (or as close as practical to) the battery or DC wiring bus system.***

Havis recommends using;

- Bussmann ANN-150 Fuse (Havis #014838) and #4164 Fuse Holder (Havis #03637).

OR

- Bussmann AMG-150 Fuse (Havis #010098) and Havis "ShortSafe" Fuse Holder D018361.

7. Connect bonding lug. Torque to 40lb-in

Use an 8AWG or larger copper conductor to connect the inverter chassis bonding lug to the vehicle chassis.

- 8. Connect the inverter to the battery. BE AWARE** that, as a large number of capacitors become charged upon completion of the DC circuit, **THERE MAY BE A LARGE SPARK** when the last battery connection is made. The spark is normal and may occur every time the batteries are connected.

Connect the black, negative DC input cable from the quick connector to the battery negative (-) terminal. This battery negative terminal is usually where the battery negative connects to the engine block or frame. Connect the red, positive DC input cable from the quick connector to the in/line fuse near the battery positive (+) terminal. The positive DC cable must be connected to the DC electrical system on the battery side of the Battery Disconnect Switch so the charger can charge the battery while the disconnect switch is OFF.

The inverter will be damaged, not covered under warranty, if the battery positive and negative cables are reversed.

- 9. Connect 12V DC OUTPUT Power terminal to DC loads.**

Connect the green one-position connector labeled 12V DC OUT to 12vdc loads. Use up to 14AWG wire. Strip wire insulation back 1/2". Push the bare wire fully into the bottom (round) opening of the green connector. To release the wire insert the supplied small flat screwdriver "straight in" into the upper (rectangular) opening.

- 10. Set the 8-position DIP Switch for the desired inverter/charger operation.**

The factory DIP Switch settings are: **1, 2, 3, 4 and 8, ON (UP); 5, 6, and 7, OFF (DOWN).**

The factory setting selects:

- 60Hz AC Output Frequency
- 50Amps DC Battery Charging Current
- Flooded Battery Type
- Load Demand Feature OFF
- 12VDC Power OUTPUT Circuit ON

Note: After changes are made to the Setup DIP Switch settings, shore power must be removed and the inverter cycled OFF/ON for the change to go into effect.

See full description of DIP Switch settings in the component identification section of this manual. The DIP Switch Function diagram is also silkscreened onto the top panel of the inverter.

11. Remote Control

The LSC12-1100 will accept one maintained remote control signal from a customer supplied remote switch. The remote control signal can be a +12vdc signal; or a GND signal; or a continuity signal.

Connect the remote control signal wire to the Remote Control & Alarm Terminal Block. Use up to 14AWG wire. Strip insulation back 3/8". Push the bare wire straight into the bottom (rounded) opening. Be sure the bare wire is fully inserted and not touching sheet metal or an adjacent terminal. To release the wire use a thumbnail or small tool to press the grooved button above the wire.

If using a +12VDC Remote Control Signal, insert the signal wire into Terminal 4, ENB+.

If using a GND Remote Control Signal, insert the signal wire into Terminal 5, ENB-.

If using a two-wire continuity signal, insert the wires into Terminals 5 and 6, ENB- and GND.

Set the ON/OFF/REMOTE Switch to the REMOTE position.

DO NOT apply +12v to the GND terminal. This would create a dead short and may damage the unit.

Deactivate remote control by setting the ON/OFF/REMOTE Switch to the ON or to the OFF position.

Remote control switch arrangements for remote control of inverter.

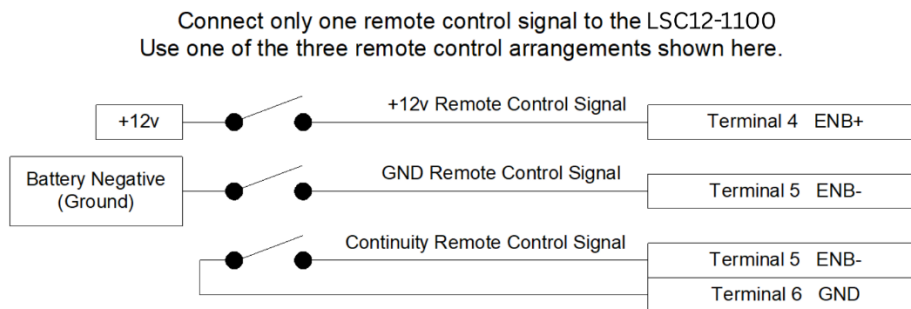

Note: The LSC12-1100 is designed to accept ONLY ONE remote control signal. If more than one of the signals shown above are connected to the inverter, it won't harm the unit but would provide undesirable operation since the signals will be performing "in parallel".

It is common for an ambulance to have two remote control switches. One approach to accomplish this is to connect the switches in series. Have the first switch provide one of the signals shown above. Have the second switch provide continuity between the first switch and the inverter.

For a two-switch remote control arrangement where one switch provides a +12v signal and the other switch provides a GND signal, an automotive relay will need to be added. This may be the case when the LSC12-1100 is replacing an older inverter. See Automotive Relay sketch on the next page.

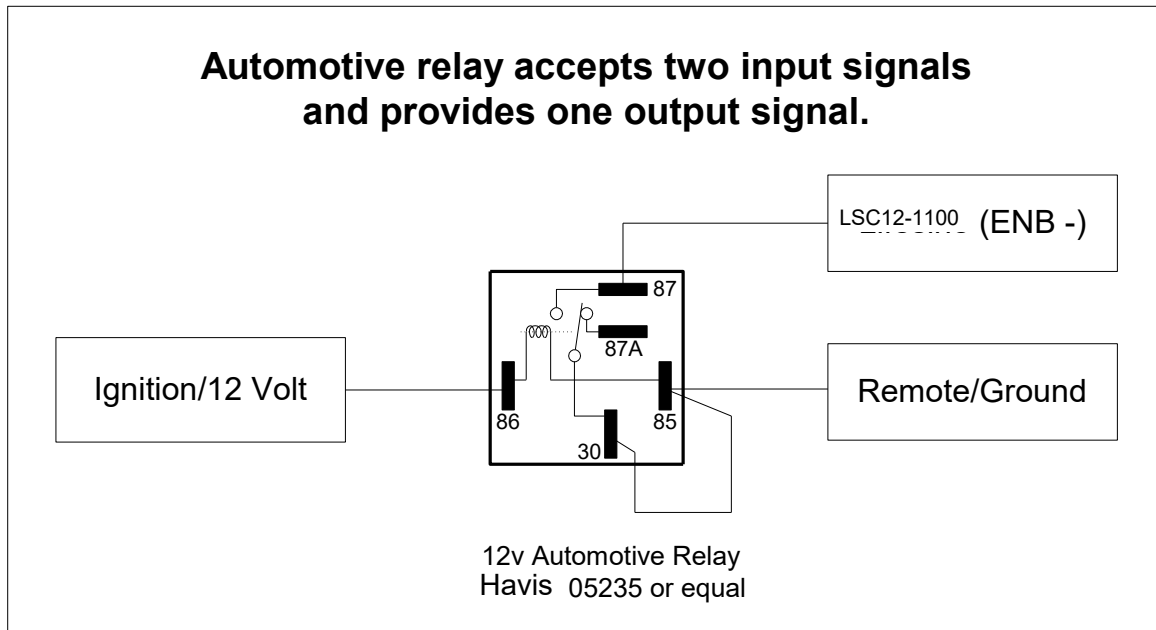

Automotive Relay Sketch

Trouble Shooting Note:

Symptom: The LSC12-1100 inverter does not turn OFF when the remote switch is turned OFF.

Cause: Older Havis ambulance inverter remote control arrangements, could accept two remote control signals. The inverter treated two remote signals as if two switches were operating in series. (Both signals had to be ON for the inverter to turn ON. If either signal turned OFF, the inverter turned OFF.)

The LSC12-1100 will treat these same two signals as if two switches are connected in PARALLEL. (If either signal is ON the inverter is ON. Both signals must be OFF for the inverter to be OFF.)

Solution: Add an automotive relay to accept two input signals and provide one output signal to the LSC12-1100.

12. Connect the AC loads.
Connect (plug in) the AC loads into the inverter's GFCI receptacle.
13. Verify installation.
Verify all connections are tight and secure.

SECTION 9: INSTALLATION AND FUNCTION OF THE LSCR AND LSIR REMOTE STATUS DISPLAY PANELS.

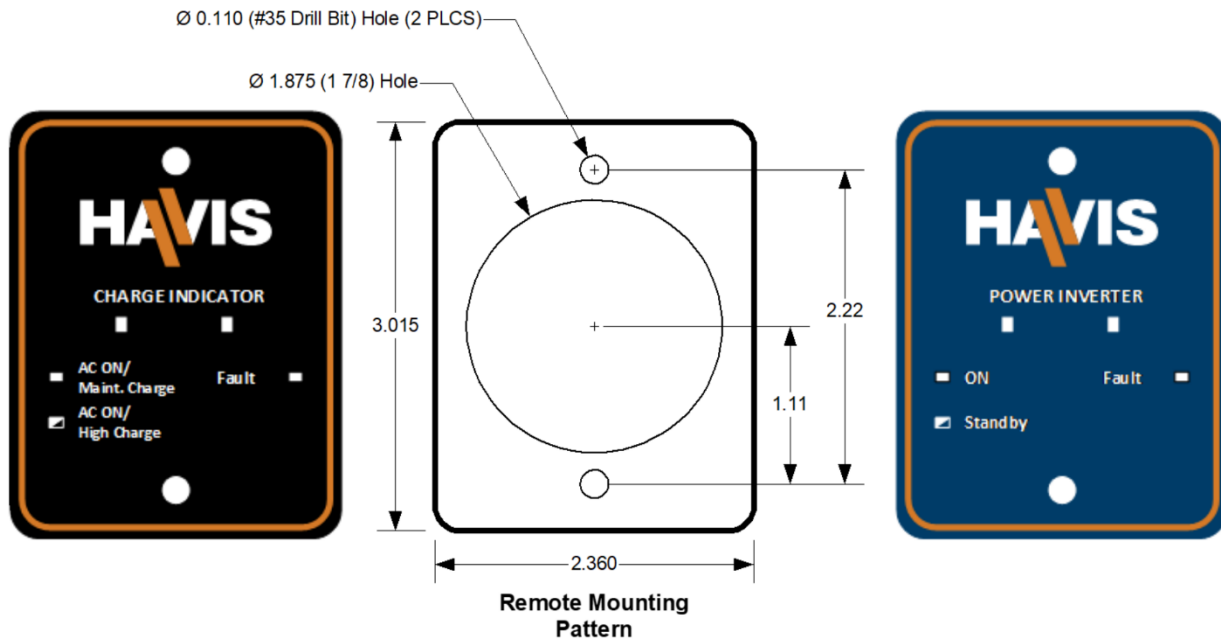

Two optional remote status display panels are available for the LSC12-1100. One is for Charger Status (Part Number – **LSCR**) and the other is for Inverter Status (Part Number – **LSIR**). (These are the same remote status display panels used with the Havis 20-1050CUL-DC inverter/charger.) Both the Charger and Inverter Remote Status Display Panels contain a green and a red LED indicator light. On the charger status panel, a FLASHING green LED indicates the presence of shore power and the charger is in Bulk or Absorption Stage. A SOLID green LED indicates the presence of shore power and that the charger is in Float stage. On the inverter status panel, the SOLID green LED indicates the unit is ON. A FLASHING green LED indicates the inverter is in Standby mode. (“Inverter in standby mode” is when the inverter switch is ON while the LSC12-1100 is in Battery Charger mode. If shore power is lost, the inverter will turn on and supply power to the AC loads.) For both the remotes panels, the red Fault LED indicates problems such as over temperature, output overload, or low battery. The remote status panels do not provide remote control.

The panels have a gasket seal which will keep the electronics safe from weather and water spray. Each panel is equipped with a RJ45 connector for easy installation and replacement. The panels are available without cables (LSCR or LSIR), or with a 13’ cable (LSCR-13, LSIR-13) or with 25’ cable (LSCR-25, LSIR-25).

The following installation procedure applies to remote status panels.

- Step 1: Select a location for the panel.
 Identify the desired location for the inverter and/or charger panels.

- Step 2: Route cable.
 Carefully route the modular cable from the front of the LSC12-1100 to the remote location. This cable does not need to be shielded but it should be routed away from the AC cables.

Step 3: Secure panel to surface.

Remove the protective liner from the gasket and mount the panel using the provided #8 screws through the two holes in the panel.

Remote Status Display Panel Indicator LED's

Scenario #	Status of LSC12-1100	LSIR		LSCR	
		Status LED	Fault LED	Status LED	Fault LED
1	Inverter ON	Green	OFF	OFF	OFF
2	Inverter in Standby/Load Demand	Double Blink Green every 10 seconds	OFF	OFF	OFF
3	Charger in Bulk/High/Absorption. Inverter switch OFF	OFF	OFF	Blinking Green	OFF
4	Charger in Bulk/High/Absorption. Inverter switch ON	Blinking Green	OFF	Blinking Green	OFF
5	Charger in Float/Maintenance. Inverter switch OFF	OFF	OFF	Green	OFF
6	Charger in Float/Maintenance. Inverter switch ON	Blinking Green	OFF	Green	OFF
7	Low Battery Warning	OFF	Red	OFF	Red
8	Low Battery Shutdown	Blinking Green	Red	Blinking Green	Red
9	Overload Shutdown	Blinking Green	Red	Blinking Green	Red
10	Overtemp Shutdown	OFF	Red	OFF	Red

SECTION 10: OPERATING THE LSC12-1100

Use the following instructions to operate the LSC12-1100.

- Step 1 Install the LSC12-1100 unit.
 Completely install the inverter/ charger using the instructions provided in earlier section of this manual. DIP Switch setting should be 1-4 and 8 ON (up), 5-7 OFF (down).
- Step 2: Start the vehicle.
- Step 3: Turn the remote switch ON.
- Step 4: Set the Inverter ON/OFF/REMOTE Switch to the REMOTE position.
 The inverter Status LED will be ON solid indicating that the inverter is ON.
- Step 5 Verify AC Output Power
 Apply an AC load, such as a shop light or drill, to the inverter's GFCI receptacle. Verify operation.
- Step 6: Apply shore power
 Turn vehicle OFF. Apply shore power to the LSC12-1100 via vehicle shore power connection. After several seconds the unit will accept shore power. The Charger Status LED will blink or be on solid. AC loads will be operating.
- Step 7: Observe Transfer Switch.
 Remove shore power from the LSC12-1100. The unit will automatically switch to Inverter mode and operate the AC loads using battery power. When shore power is restored, the unit examines the AC input for several seconds and then switches the AC loads back to be powered by shore power.
- Step 8: Turn Remote Switches OFF.
 The inverter will turn OFF.

SECTION 11: FAULT SHUTDOWN CONDITIONS AND SOLUTIONS

System Status LED	Fast or Slow Blinking	Beeper states	Fault Condition	Solution
Green	— — — Slow Blink	Two Short	Over Temperature Shutdown	<ol style="list-style-type: none"> 1. Improve ventilation. Verify the inverter's ventilation openings are not obstructed. 2. Reduce ambient temperature.
Orange	— — — Slow Blink	N/A	AC Input Over / Under Voltage Shutdown	<ol style="list-style-type: none"> 1. Verify the AC input voltage is between 90Vac ~ 132Vac
	••••• Fast Blink	N/A	AC Input Over Current Shutdown	<ol style="list-style-type: none"> 1. Reduce the AC load. Check for AC output short circuit.
	————— Solid	N/A	Phase or Frequency Failure	<ol style="list-style-type: none"> 1. Verify DIP Switch 1 is ON (UP) and AC input frequency is 60Hz.
Red	— — — Slow Blink	Four Short	Battery Under Voltage Shutdown	<ol style="list-style-type: none"> 1. Increase DC input voltage. 2. Check DC input connection and DC cable connections. 3. Recharge battery.
	••••• Fast Blink	Three Short	Battery Over Voltage Shutdown	<ol style="list-style-type: none"> 1. Reduce DC input voltage.
	————— Solid	Five Short	Overload (101%~115%)	<ol style="list-style-type: none"> 1. Reduce AC load.
	N/A	Overload (>115%) / Short Circuit		

If the inverter has shut down for a fault, correct the reason for the fault and then reset the inverter by cycling the ON/OFF/REMOTE Switch, or a remote switch, OFF and back ON.

SECTION 12: TROUBLESHOOTING THE LSC12-1100

The following are the most common questions heard by Havis service professionals. If your situation does not apply to the following categories, please contact your local Havis Inc Distributor or Havis Customer Service: **1-614-771-3559, VSI Technical Support.**

SYMPTOM ON lamp fully illuminates. AC load does not run.

SOLUTION Check and reset the GFCI receptacle.

Verify AC load and cord is in proper condition.

SYMPTOM BATTERY LOW lamp illuminates when AC load is applied.

SOLUTION Check battery connections.

Check battery condition.

Recharge battery if voltage is less than 10.5 VDC.

Check the vehicle's alternator charging system for proper operation.

SYMPTOM DC fuse blows when connecting DC input cables.

SOLUTION Check for reverse polarity. The battery positive and negative cables may be connected to the inverter backwards. The unit may be damaged and require repair service.

Symptom Battery Charging Amps is set for 50 amps but output does not reach 50 amps. Battery voltage is not climbing.

Solution Reduce the AC loads connected to the inverter. The Automatic Power Management feature reduces battery charging power as needed so AC INPUT current does not exceed 12amps.

Symptom Battery Charging is intermittent, or charger is OFF while A/C shore power is applied.

Solution Verify wires inside A/C input plug are seated correctly and tight. Replace worn A/C input plug at auto-eject/vehicle connection. Replace shore power cable input plug biennial (every other year) to maintain proper shore power charging operation

Notes



4282 Reynolds Drive

Hilliard, Ohio 43026

Toll free 1-800-AC POWER (1-800-227-6937)

Tel: 614-771-2718

www.havis.com

Owner's Manual Part Number D919952

March, 3rd 2026