

INSTALLATION INSTRUCTIONS

P-REAR-1 W/P-MFK-9

REAR PARTITION W/FILLER PANEL MOUNTING KIT

1997-2026 CHEVROLET PASSENGER VANS

TOOLS REQUIRED:

Power drill	Drill bit set	Standard socket set
Ratcheting wrench	Rivet nut insert tool	Utility knife

COMPONENTS:

<u>QTY</u>	<u>DESCRIPTION</u>	<u>PART #</u>
1	Partition	P-REAR-1
1	Mounting Filler Kit	P-MFK-9

P-MFK-9 COMPONENTS:

<u>QTY</u>	<u>DESCRIPTION</u>	<u>PART #</u>
1	Passenger Side Filler Panel	110-000059
1	Driver Side Filler Panel	110-000060

HARDWARE:

<u>QTY</u>	<u>DESCRIPTION</u>	<u>PART #</u>
4	1/4" Nylock nut	GSM30016
16	1/4" Serrated nut	GSM30023
11	1/4" Rivnut	GSM30140
19	1/4" Flat washer	GSM31005
11	1/4" Split lock washer	GSM31026
12	1/4" x 1/2" Carriage bolt	GSM31999
4	1/4" x 3/4" Carriage bolt	GSM32000
8	1/4" x 3/4" Bolt	GSM33001
5	1/4" x 1.25" Bolt	GSM33003
2	1/4" x 3" Bolt	GSM33009
2	2" Aluminum spacer	GSM34607
2	Partition midway "L" bracket	HS-PA99040

Always!

- Read all instructions before installing any Havis, Inc. products.
- **Check for obstructions (Wires, brake lines, fuel tank, etc.) before drilling any holes!**
- Use hardware provided with install kit

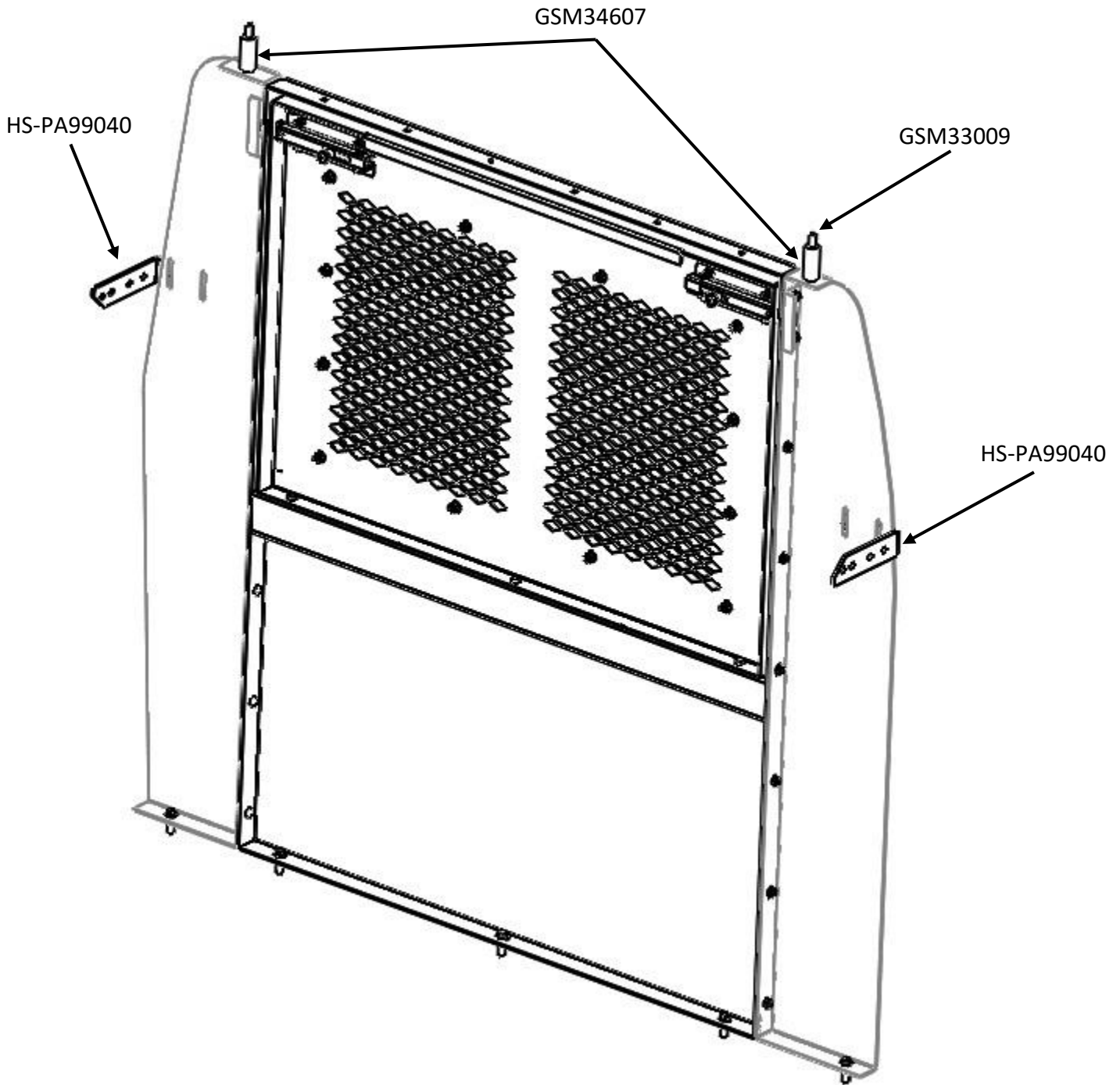



Place partition in van



Make sure the floor is level and even. It should be 8.5" from door opening.



Pre-drill two (2) 1/8" pilot holes in top trim and metal cross support. Use holes in partition frame to determine drill location.
Upper trim panel has been removed to show detail.



Pre-drill five (5) 1/8" pilot holes into floor at bottom of partition.



Remove partition and upper plastic trim panel. Drill upper pilot holes in metal frame out to 25/64"



Remove lower plastic sill plate and drill lower holes out to 25/64"



Install 1/4" rivnuts into the holes and tighten using a rivnut gun or rivnut tool.

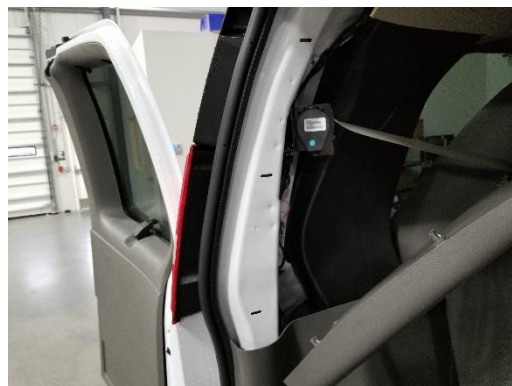

Remove upper side trim panels.

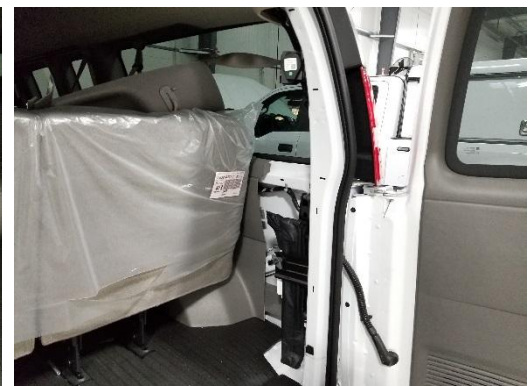

Repeat process for passenger side.

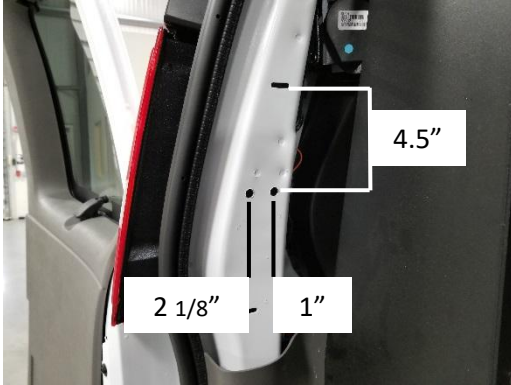

Follow measurements shown above. Drill and install two (2) rivnuts in rear side pillar.

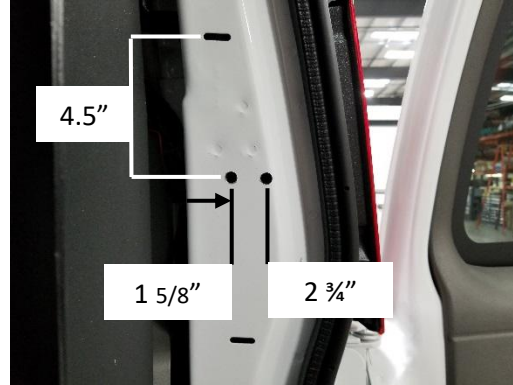

Repeat process for passenger side.



Install side brackets using 1/4" x 3/4" bolts, lock washers and flat washers.



Mark and cut trim panel as needed for bracket to come through.



Repeat process for passenger side.



Replace upper trim panel. Drill upper plastic panel only at mount location with 1" hole saw to allow spacer to be installed.



Install (5) 1/4" x 1.25" bolts, split washers, and flat washers along bottom floor mounting,



Install 2" spacers at top of partition and install 3" bolts and washers.

Install 1/4" x 3/4" bolts, flat washers, and nylon nuts to side "L" brackets.



Install emergency exit hatch. Installation is now complete.