

K9-C29 & K9-C29-B K9-C29-SDS-3 & K9-C29-SDS-3 B

INSTALLATION INSTRUCTIONS

TOOLS REQUIRED: K9 Kit for 2021-2025 CHEVROLET SILVERADO

| | | | |
|-----------------------|------------------------|-------------------------|--------------------|
| Phillips Screw Driver | Metric Socket set | Trim panel removal tool | Caulk Gun |
| Standard Socket set | Wire Cutters /Crimpers | | Drill & Drill bits |

PARTS and MOUNTING HARDWARE:

| <u>QTY</u> | <u>DESCRIPTION</u> | <u>ITEM#</u> | |
|------------|------------------------------|---------------|---------------|
| 2 | Front floor mounting bracket | 42103 | |
| 2 | Rear floor mount bracket | 42104 | |
| 1 | Floor | 42095 – White | 42094 – Black |
| 2 | Floor support | 42102 | |
| 1 | Cross support | 42106 | |
| 1 | Tunnel bracket | 42107 | |
| 1 | Rear filler plate | 22952 – White | 23500 – Black |
| 1 | Rear bulkhead | 42099 – White | 42098 – Black |
| 1 | Front bulkhead | 42097 – White | 42096 – Black |
| 1 | Rear window | 42105 | |
| 2 | Lower “B” pillar bracket | 42108 | |
| 2 | Upper “B” pillar bracket | 42109 | |
| 1 | Ceiling | 42101 – White | 42100 – Black |
| 1 | DS side curtain panel | 42111 – White | 42110 – Black |
| 1 | PS side curtain panel | 42113 – White | 42112 – Black |
| 1 | DS Door panel | 42115 – White | 42114 – Black |
| 1 | PS Door panel | 42117 – White | 42116 – Black |
| 1 | DS Window guard | 42118 | |
| 1 | PS Window guard | 42119 | |
| 1 | Floor mat | 43006 | |
| 1 | Dome light kit | 17987 | |
| 1 | Silicone | 20011 – White | 20012 – Black |
| 1 | Rear brace | 43007 | |

HARDWARE

| <u>QTY</u> | <u>DESCRIPTION</u> | <u>ITEM#</u> |
|------------|----------------------------|--------------|
| 20 | 1/4" x 3/4" Carriage bolt | 16235 |
| 76 | 1/4" Flat washer | 16154 |
| 72 | 1/4" Phillips screw | 16618 |
| 40 | 1/4" Serrated nut | 16086 |
| 32 | #10 x 1/2" Screw | 16655 |
| 10 | #10 x 1/2" Flat head screw | 16641 |

Always!

- Read all instructions before installing any Havis, Inc. products.
- **Check for obstructions (Wires, brake lines, fuel tank, etc.) before drilling any holes!**
- Use hardware provided with install kit

K9-C29 Assembly

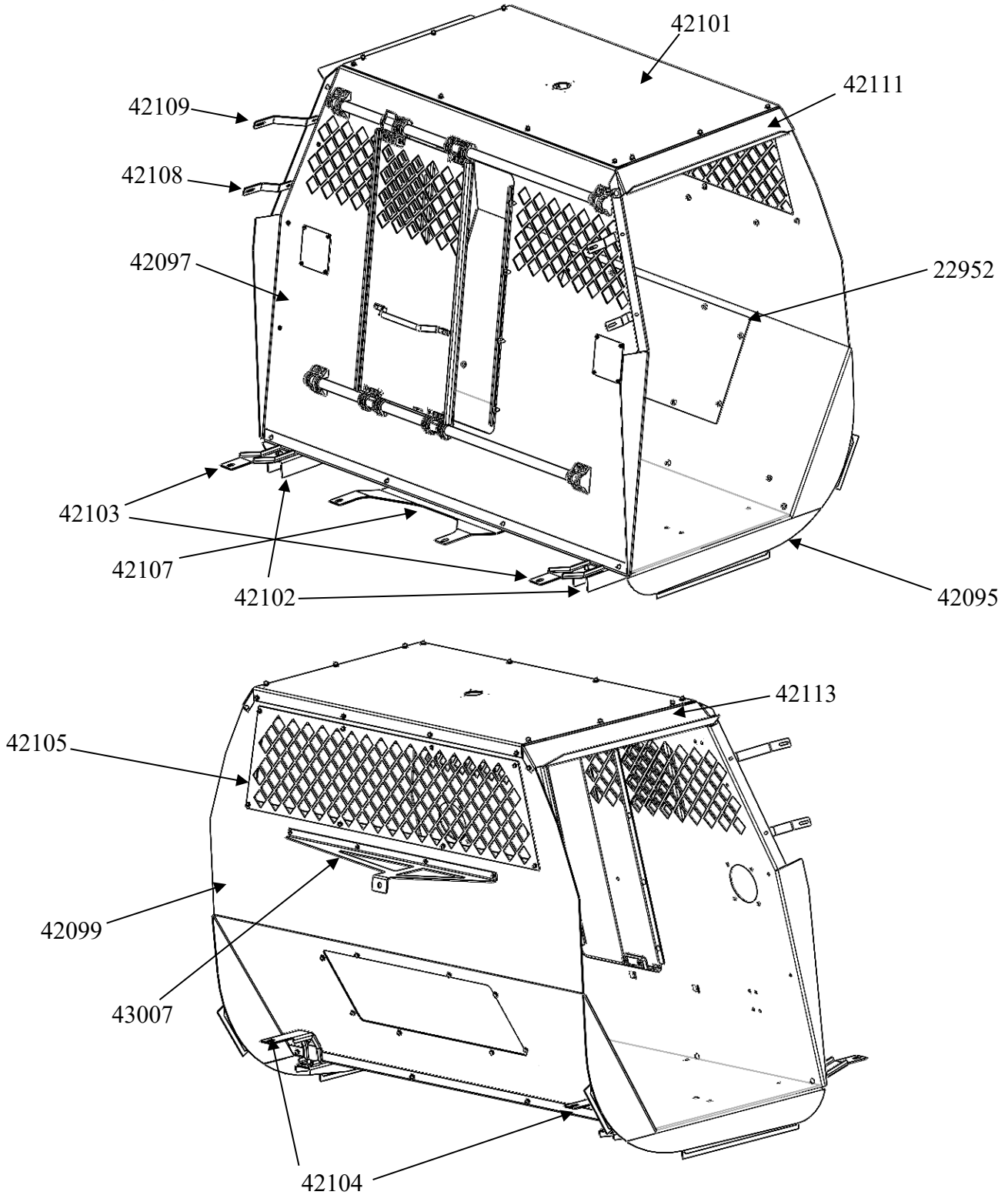

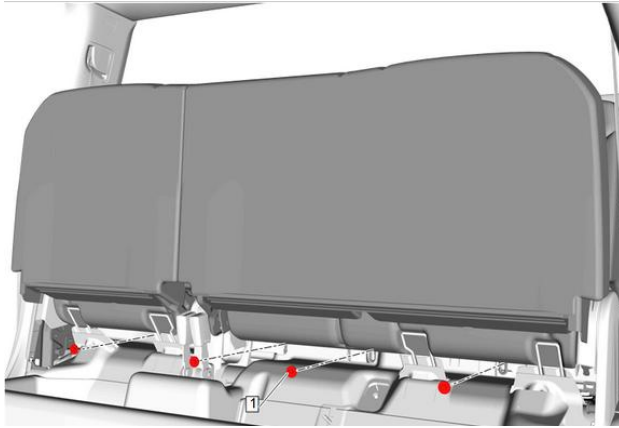

Remove all the bolts of the rear seat.



Remove the headrest and the headrest guide.

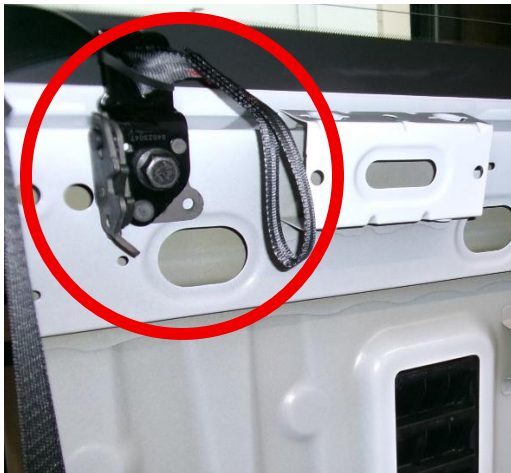

Find the three rear seats back latch.



Push up the rear seat back latch to remove the seats. Remove the middle latch.



Remove the jack and relocate where appropriate.



Remove rearmost bolts of front seat tracks and the center seat or console. Slide tunnel bracket under seat tracks and loosely reinstall hardware.



Place supports on floor. Slide front brackets under seat tracks and loosely install 1/4" Phillips screw and 1/4" Flat washer.



Install rear brackets to seat mounts using rear seat hardware.



Assembled floor bracketry should look as shown. Some hardware in photos has changed for production.



Attach floor stiffener to floor panel with 1/4" Phillips screw and 1/4" flat washer.



Install floor panel, align to be centered and square, and tighten all hardware.



Replace grab handles with B-pillar brackets, leaving trim loose.



Loosely install bulkheads, rear support, and roof panel using the 1/4" Phillip screw, 1/4" Flat washer, 1/4" x 3/4" Carriage bolt and 1/4" Serrated nut.



Attach B-pillar brackets and tighten hardware.
Reinstall trim once tight.



If installing side drawer storage see last page.
Tighten remaining loose bulkhead and bracket hardware.



Hook top of side curtain panels over bulkhead and rotate up into place to install.



Install and tighten side curtain hardware.



Install door panels and window guards, insert floor mat, install rear cover panel and window using #10 x 1/2" Screw and #10 x 1/2" Flat head screw. Install any optional accessories at this time.

K9-A-119 & K9-A-119-B INSTALLATION INSTRUCTIONS

TOOLS REQUIRED:

Phillips Screw Driver Metric Socket set Trim panel removal tool Caulk Gun
 Standard Socket set Wire Cutters /Crimpers Drill & Drill bits

PARTS and MOUNTING HARDWARE:

| <u>QTY</u> | <u>DESCRIPTION</u> | <u>ITEM#</u> | |
|------------|--------------------|---------------|---------------|
| 1 | Panel divider | 43491 – White | 43490 – Black |
| 1 | Panel top shelf | 43493 – White | 43492 – Black |
| 1 | Panel middle shelf | 43495 – White | 43494 – Black |
| 1 | Panel Lower shelf | 43497 – White | 43496 – Black |

HARDWARE

| <u>QTY</u> | <u>DESCRIPTION</u> | <u>ITEM#</u> |
|------------|---|--------------|
| 9 | 1/4" Serrated nut | 16086 |
| 10 | 1/4" Flat washer | 16154 |
| 9 | 1/4" x 3/4" Carriage bolt | 16235 |
| 10 | 1/4" Phillips screw | 16618 |
| 3 | 1/4 x 3/4" Hex SEMS bolt (self-threading) | 16359 |

Always!

- Read all instructions before installing any Havis, Inc. products.
- **Check for obstructions (Wires, brake lines, fuel tank, etc.) before drilling any holes!**
- Use hardware provided with install kit

K9-A-119 Assembly

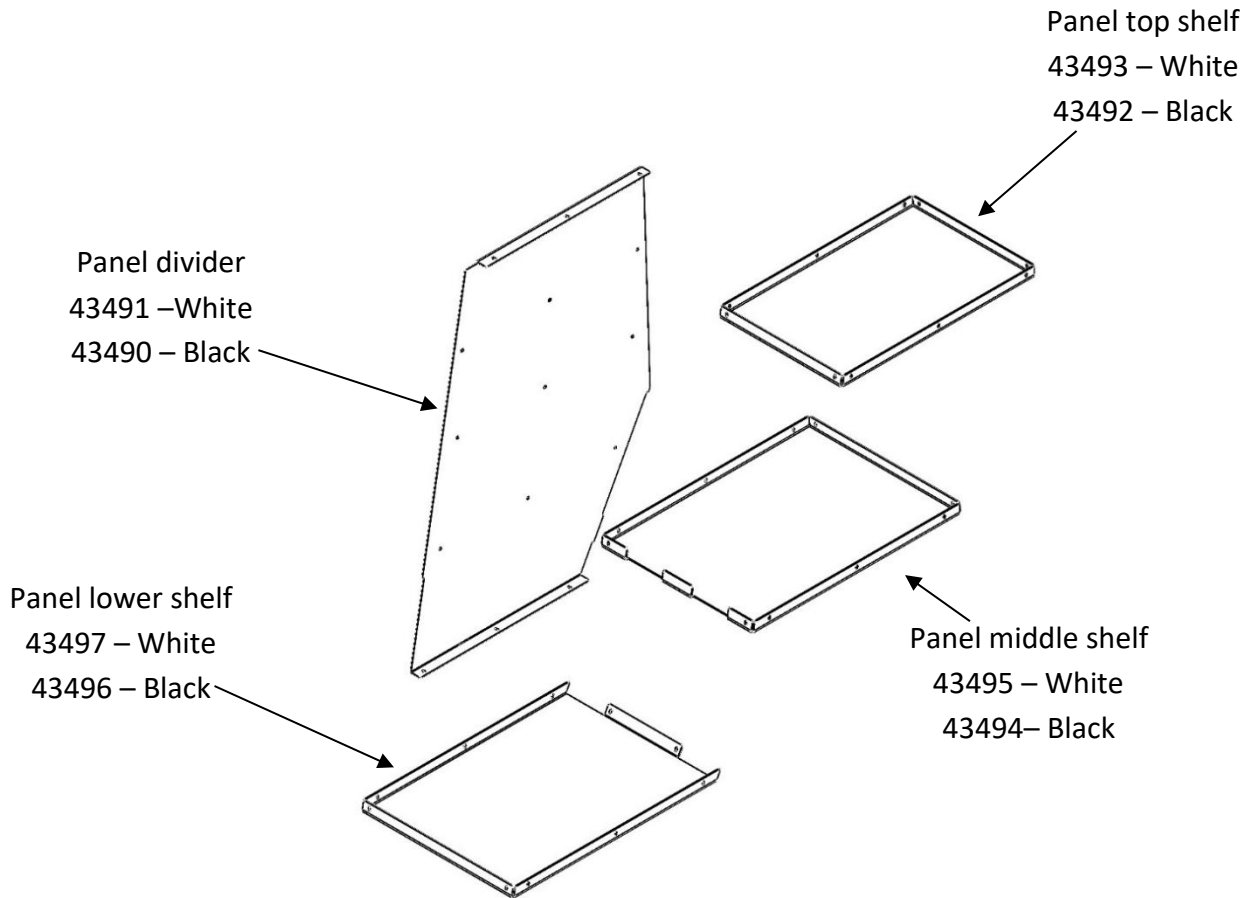

Install the panel divider.



Install the three shelves.