

UNIT ASSEMBLY

TOOLS LIST:

1. 4MM HEX WRENCH OR FIT WITH DRIVER
2. 2.5MM HEX WRENCH OR BIT WITH DRIVER

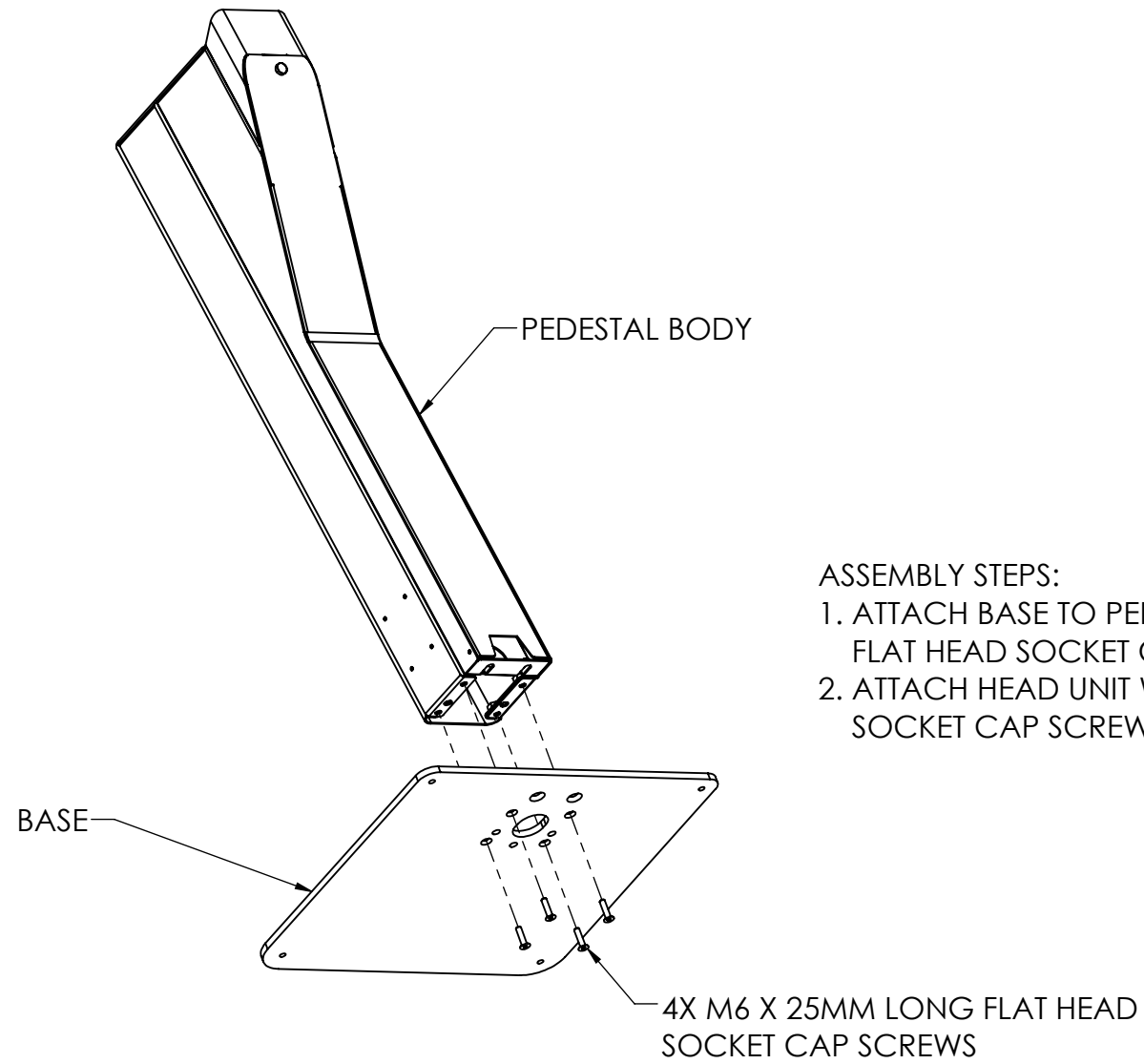

ASSEMBLY STEPS:

1. ATTACH BASE TO PEDESTAL BODY WITH 4X M6 X 25MM LONG FLAT HEAD SOCKET CAP SCREWS AS SHOWN.
2. ATTACH HEAD UNIT WITH 4X M4 X 8MM LONG FLAT HEAD SOCKET CAP SCREWS AS SHOWN.

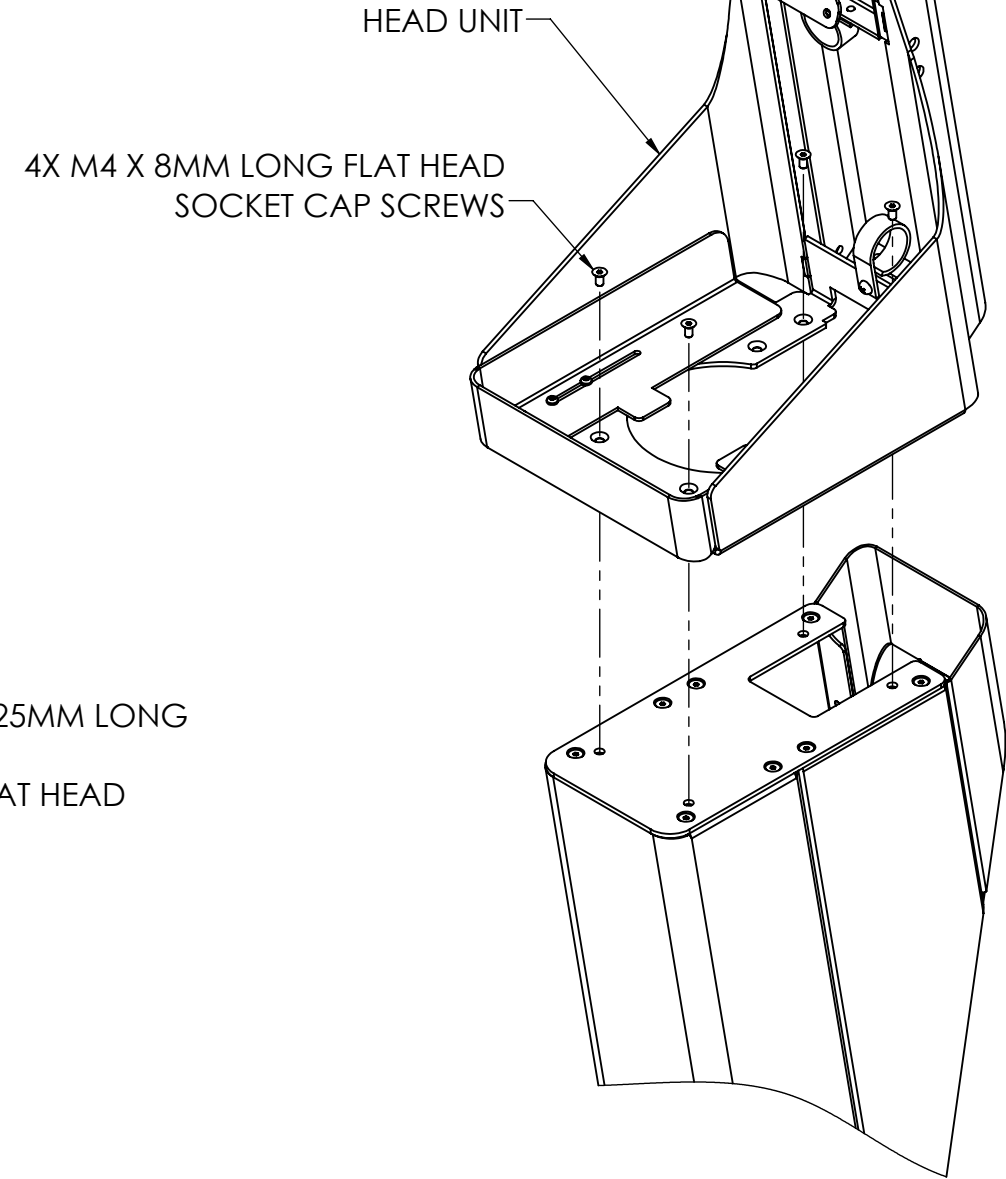

DWG. NO. SC-1000-PF	REV. D	TITLE SELF CHECK-OUT, PEDESTAL MOUNTED, FREE STANDING		SHEET 1 OF 2
DRAWN S. YANG	DATE 3/27/2023			

THE INFORMATION CONTAINED IN THIS DRAWING IS THE SOLE PROPERTY OF HAVIS, INC. AND REPRODUCTION IN PART OR IN WHOLE WITHOUT THE WRITTEN PERMISSION OF HAVIS, INC. IS PROHIBITED.

CUSTOMER INSTRUCTIONS

TOOLS LIST:

1. 3MM HEX WRENCH OR BIT WITH DRIVER
2. 2.5MM HEX WRENCH OR BIT WITH DRIVER
3. #1 PHILLIPS SCREW DRIVER
4. #2 PHILLIS SCREW DRIVER

DISPLAY & PRINTER INSTALL (SOME PARTS HIDDEN FOR CLARITY)

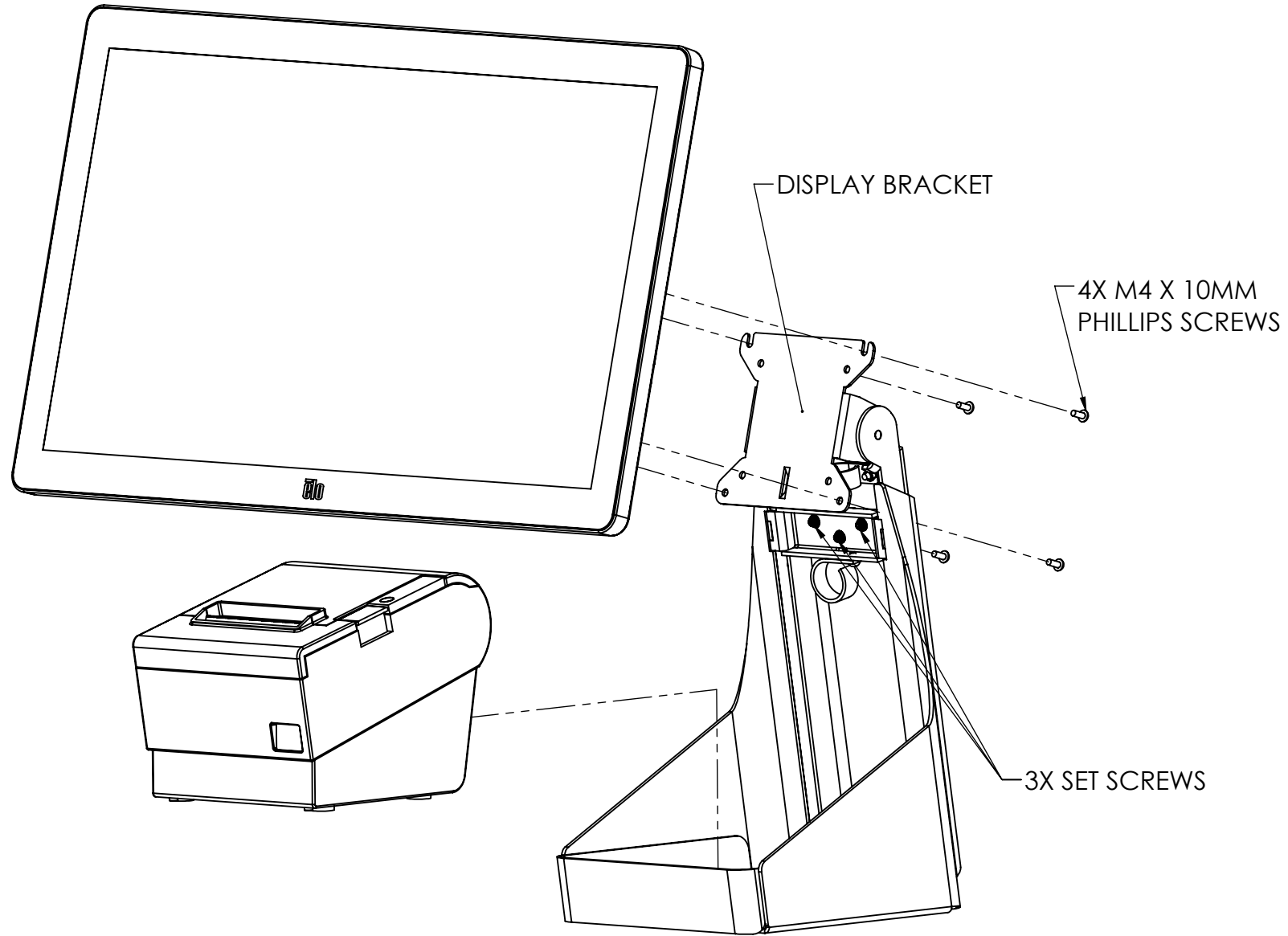
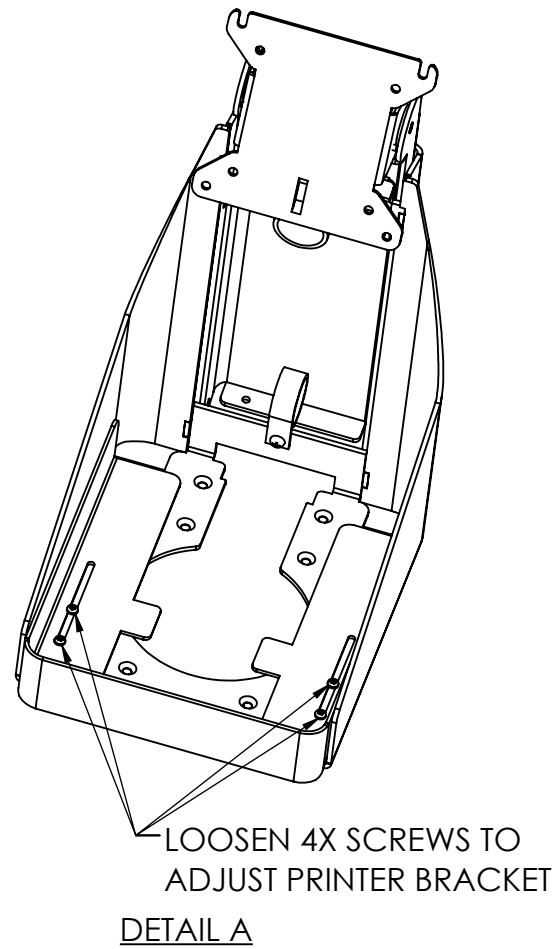

ASSEMBLY STEPS:

1. LOOSEN 3X SET SCREWS.
2. HOLD DISPLAY ATTACHMENT BRACKET AT DESIRED HEIGHT.
3. TIGHTEN 2X SET SCREWS.
4. ATTACH DISPLAY WITH 4X M4 X 10MM LONG PHILLIPS SCREWS.
5. PLACE PRINTER INTO SC-1000-CF UNIT. 4X SCREWS CAN BE LOOSENED TO ADJUST PRINTER BRACKET (SEE DETAIL A).
(OPTIONAL) DUAL LOCK (2 STRIPS INCLUDED) CAN BE USED UNDER THE PRINTER TO HOLD IT IN PLACE IF DESIRED.

DWG. NO.
SC-1000-PF

REV.
D

TITLE

SELF CHECK-OUT,
PEDESTAL MOUNTED,
FREE STANDING

HAVIS

SHEET 2 OF 2

CUSTOMER INSTRUCTIONS